

# Q2A

### Driving Quality

- Advanced motor control for IM, PM & SynRM motors
- Open/closed loop speed or torque control
- Embedded functional safety (STO SIL3)
- Built-in C3 class EMC filter
- Conform to EN 60721-3-3, 3S2 and 3C2
- Built-in braking transistor (models up to 90 kW)
- Quick and easy setup with intuitive keypad and navigation
- Micro SD for data storage
- Real-Time Clock
- 24 VDC power supply input for control board
- Communication options: EtherCAT, EtherNet/IP, PROFINET, Modbus TCP/IP, POWERLINK
- Up to 5 Q2A with a single communication option card
- PC configuration tools: Q2edit and Q2dev
- Mobile Device connectivity (via USB or optional Bluetooth)
- Regenerative solutions as option
- CE, UL, cUL, EAC, RoHS

### Ratings

- 200 V class: 0.55 to 110 kW
- 400 V class: 0.55 to 315 kW



## System configuration

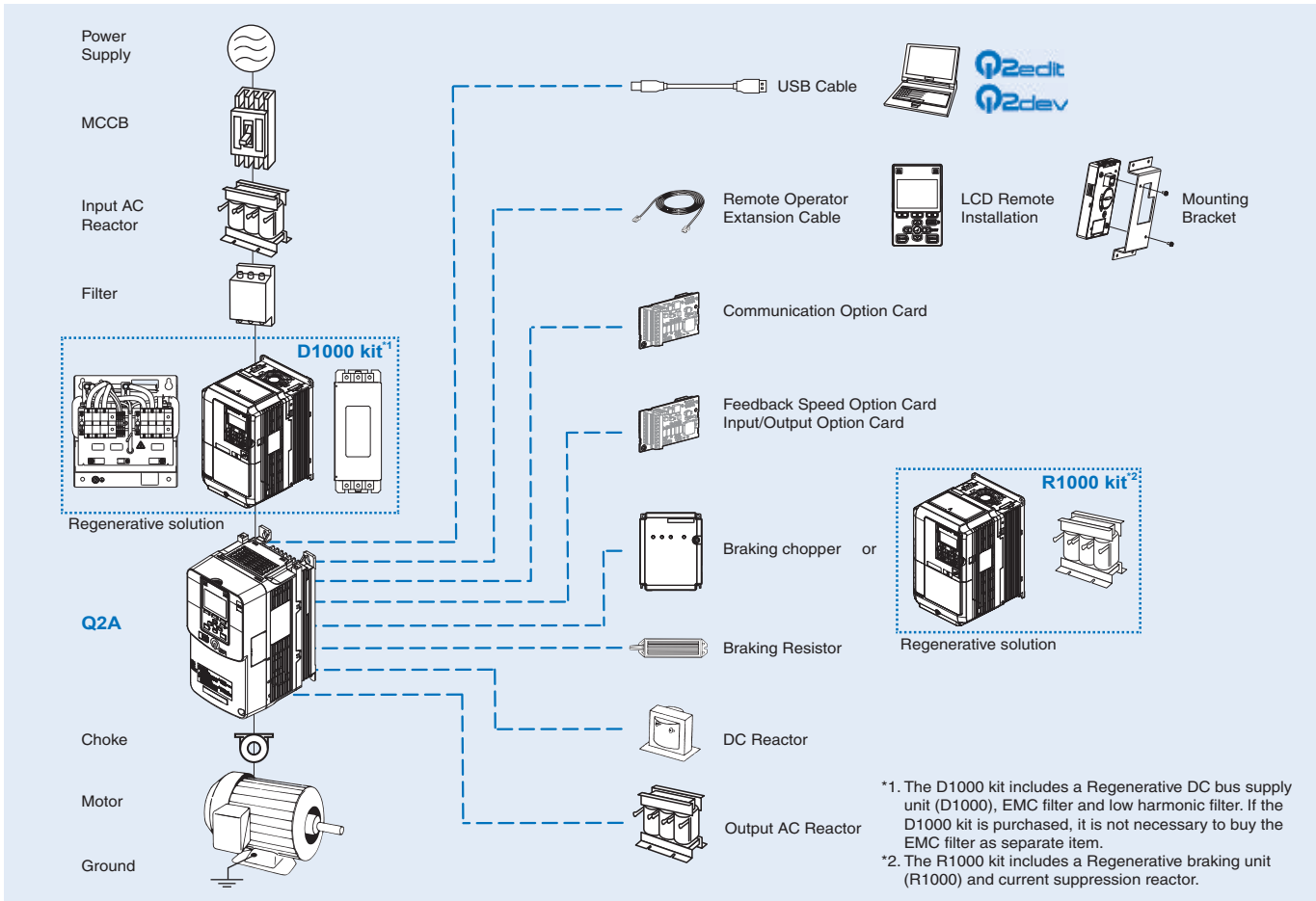

Specifications

Type designation

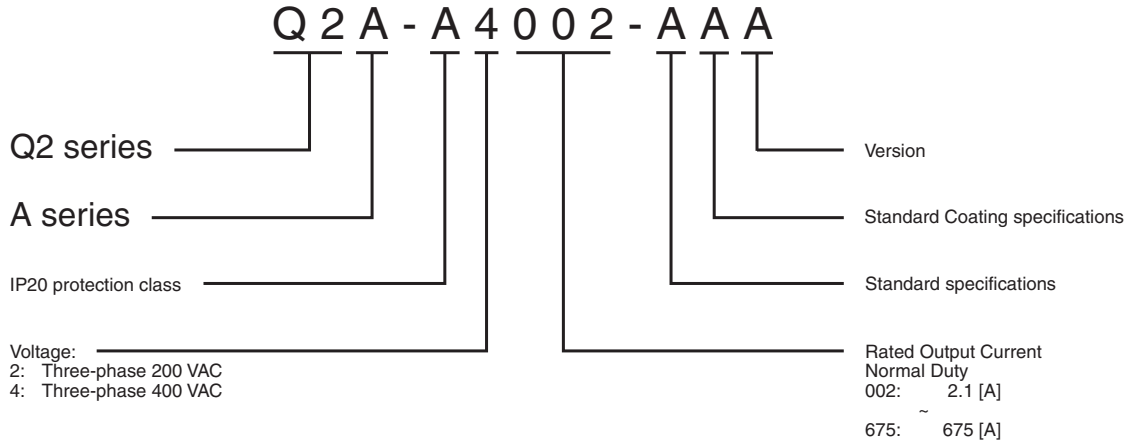

200 V class

Q2A-A□		Duty rating	2004	2006	2010	2012	2021	2030	2042	2056	2070
Max. applicable motor output (kW)	HD <sup>*1</sup>		0.55	0.75	1.5	2.2	4.0	5.5	7.5	11	15
	ND <sup>*2</sup>		0.75	1.1	2.2	3.0	5.5	7.5	11	15	18.5
Inverter capacity (kVA)	HD <sup>*3</sup>		1.2	1.9	3.0	4.2	6.7	9.5	12.6	17.9	22.9
	ND <sup>*4</sup>		1.3	2.3	3.7	4.6	8.0	11.4	16	21.3	26.7
Rated output current (A)	HD		3.2	5.0	8.0	11	17.5	25	33	47	60
	ND		3.5	6.0	9.6	12.2	21	30	42	56	70
Output characteristics	Overload tolerance <sup>*5</sup>		<ul style="list-style-type: none"> <li>HD: 150% of the rated output current for 60 seconds</li> <li>ND: 110% of the rated output current for 60 seconds</li> </ul>								
	Carrier frequency <sup>*6</sup> (without derating the drive capacity)		<ul style="list-style-type: none"> <li>HD: 8 kHz</li> <li>ND: 2 kHz</li> </ul>								
	Max. output voltage		Proportional to input voltage: 200-240 V								
	Max. output frequency		<ul style="list-style-type: none"> <li>AOLV, EZOLV: 120 Hz</li> <li>CL-V/f, CLV, AOLV/PM, CLV/PM: 400 Hz</li> <li>V/f, OLV, OLV/PM: 590 Hz</li> </ul>								
	Rated voltage and frequency		<ul style="list-style-type: none"> <li>3-phase AC power supply 200-240 V at 50/60 Hz</li> <li>DC power supply 270-340 VDC</li> </ul>								
Power supply	Allowable voltage fluctuation		-15% to +10%								
	Allowable frequency fluctuation		±5%								
	Input Power (kVA)	HD	1.5	2.0	3.7	5.3	8.6	12.5	16.8	24.2	32.6
ND		2.0	2.8	5.3	7.1	12.5	16.8	21.6	32.6	39.9	39.9
Weight (kg)		3.5					3.9	4.2		6	8.5

Q2A-A□		Duty rating	2082	2110	2138	2169	2211	2257	2313	2360	2415
Max. applicable motor output (kW)	HD <sup>*1</sup>	18.5	22	30	37	45	55	75	90	110	110
	ND <sup>*2</sup>	22	30	37	45	55	75	90	110	110	—
Inverter capacity (kVA)	HD <sup>*3</sup>	28.6	33.5	43.8	55.3	68.6	81.9	108	132	158	158
	ND <sup>*4</sup>	31.2	41.9	52.6	64.4	80.4	97.9	119	137	—	—
Rated output current (A)	HD	75	88	115	145	180	215	283	346	415	415
	ND	82	110	138	169	211	257	313	360	—	—
Overload tolerance <sup>*5</sup>		<ul style="list-style-type: none"> <li>HD: 150% of the rated output current for 60 seconds</li> <li>ND: 110% of the rated output current for 60 seconds</li> </ul>									
Carrier frequency <sup>*6</sup> (without derating the drive capacity)		<ul style="list-style-type: none"> <li>HD: 8 kHz</li> <li>ND: 2 kHz</li> </ul>					<ul style="list-style-type: none"> <li>HD: 5 kHz</li> <li>ND: 2 kHz</li> </ul>				
Max. output voltage		Proportional to input voltage: 200-240 V									
Max. output frequency		<ul style="list-style-type: none"> <li>AOLV, EZOLV: 120 Hz</li> <li>CL-V/f, CLV, AOLV/PM, CLV/PM: 400 Hz</li> <li>V/f, OLV, OLV/PM: 590 Hz</li> </ul>									
Rated voltage and frequency		<ul style="list-style-type: none"> <li>3-phase AC power supply 200-240 V at 50/60 Hz</li> <li>DC power supply 270-340 VDC</li> </ul>									
Allowable voltage fluctuation		-15% to +10%									
Allowable frequency fluctuation		±5%									
Input Power (kVA)	HD	39.9	34.1	46.1	56.5	68.2	83.1	113	135	164	164
	ND	47.4	46.1	56.5	68.2	83.1	113	135	164	—	—
Weight (kg)		9.0	22	24	39	40	67	104	119	119	119

- \*1. The maximum applicable motor output complies with 208 V motor ratings as specified in NEC Table 430.250. The rated output current of the drive output amps must be equal to or more than the motor rated current.
- \*2. The maximum applicable motor output is based on 4-pole, general-purpose 220 V motor ratings. The rated output current of the drive output amps must be equal to or more than the motor rated current.
- \*3. The rated output capacity is calculated with a rated output voltage of 208 V.
- \*4. The rated output capacity is calculated with a rated output voltage of 220 V.
- \*5. Derating may be necessary for applications that start and stop frequently.
- \*6. Derate the drive capacity to use values to 15 kHz maximum (2004 to 2138 models) or 10 kHz maximum (2169 to 2415 models).

400 V class

Q2A-A□		Input voltage	Duty rating	4002	4004	4005	4007	4009	4012	4018	4023	4031	4038	4044	4060	4075
Max. applicable motor output (kW)	< 460 V <sup>*1</sup>	HD	0.55	0.75	1.5	2.2	3.0	3.7	5.5	7.5	11	15	18.5	22	30	30
		ND	0.75	1.5	2.2	3.0	3.7	5.5	7.5	11	15	18.5	22	30	37	37
	≥ 460 V <sup>*2</sup>	HD	0.55	0.75	1.5	2.2	3.0	3.7	5.5	7.5	11	15	18.5	22	30	30
		ND	0.75	1.5	2.2	3.0	3.7	5.5	7.5	11	15	18.5	22	30	37	37
Inverter capacity (kVA)	< 460 V <sup>*3</sup>	HD	1.2	2.2	3.2	3.6	4.7	6.1	10	12	16	20	26	30	39	39
		ND	1.4	2.7	3.6	4.7	5.9	7.8	12	15	20	25	29	39	49	49
	≥ 460 V <sup>*4</sup>	HD	1.3	1.7	2.7	3.8	5.5	6.1	8.8	11	17	22	27	32	41	41
		ND	1.7	2.4	3.8	5.5	6.1	8.8	11	17	22	27	32	41	52	52
Rated output current (A)	< 460 V	HD	1.8	3.4	4.8	5.5	7.2	9.2	14.8	18	24	31	39	45	60	60
		ND	2.1	4.1	5.4	7.1	8.9	11.9	17.5	23.4	31	38	44	59.6	74.9	74.9
	≥ 460 V	HD	1.6	2.1	3.4	4.8	6.9	7.6	11	14	21	27	34	40	52	52
		ND	2.1	3.0	4.8	6.9	7.6	11	14	21	27	34	40	52	65	65
Overload tolerance <sup>*5</sup>		<ul style="list-style-type: none"> <li>HD: 150% of the rated output current for 60 seconds</li> <li>ND: 110% of the rated output current for 60 seconds</li> </ul>														
Carrier frequency <sup>*6</sup> (without derating the drive capacity)		<ul style="list-style-type: none"> <li>HD: 8 kHz</li> <li>ND: 2 kHz</li> </ul>														
Max. output voltage		Proportional to input voltage: 380-480 V														
Max. output frequency		<ul style="list-style-type: none"> <li>AOLV, EZOLV: 120 Hz</li> <li>CL-V/f, CLV, AOLV/PM, CLV/PM: 400 Hz</li> <li>V/f, OLV, OLV/PM: 590 Hz</li> </ul>														
Rated voltage and frequency		<ul style="list-style-type: none"> <li>3-phase AC power supply 380-480 V at 50/60 Hz</li> <li>DC power supply 513-679 VDC</li> </ul>														
Allowable voltage fluctuation		-15% to +10%														
Allowable frequency fluctuation		±5%														
Input Power (kVA)	< 460 V	HD	1.5	2.8	3.7	5.3	7.1	9.3	13	17	24	33	40	34	46	46
		ND	2.0	3.7	5.3	7.1	9.3	13	17	24	33	40	48	46	57	57
	≥ 460 V	HD	1.3	1.7	3.2	4.6	6.1	7.5	11	15	21	28	35	30	40	40
		ND	2.1	4.0	5.6	7.5	9.1	13	18	26	35	42	50	49	60	60
Weight (kg)		3.5	3.9	4.2	6.0	7.5	12	17	17	26	35	42	50	49	60	60

Q2A-A□		Input voltage	Duty rating	4089	4103	4140	4168	4208	4250	4296	4371	4389	4453	4568	4675
Max. applicable motor output (kW)	< 460 V <sup>*1</sup>	HD		37	45	55	75	90	110	132	160	200	220	250	315
		ND		45	55	75	90	110	132	160	200	220	250	315	355
	≥ 460 V <sup>*2</sup>	HD		37	45	55	75	90	110	150	185	220	260	300	335
		ND		45	55	75	90	110	150	185	220	260	300	335	370
Output characteristics	Inverter capacity (kVA)	< 460 V <sup>*3</sup>	HD	49	60	74	99	118	142	171	200	244	272	298	398
			ND	59	68	92	111	137	165	195	244	256	298	374	444
		≥ 460 V <sup>*4</sup>	HD	52	61	76	99	124	143	191	241	288	330	380	410
			ND	61	76	99	124	143	191	241	288	330	380	410	482
Rated output current (A)	< 460 V	HD		75	91	112	150	180	216	260	304	371	414	453	605
		ND		89.2	103	140	168	208	250	296	371	389	453	568	675
	≥ 460 V	HD		65	77	96	124	156	180	240	302	361	414	477	515
		ND		77	96	124	156	180	240	302	361	414	477	515	605
Overload tolerance <sup>*5</sup>			<ul style="list-style-type: none"> <li>• HD: 150% of the rated output current for 60 seconds</li> <li>• ND: 110% of the rated output current for 60 seconds</li> </ul>												
Carrier frequency <sup>*6</sup> (without derating the drive capacity)			<ul style="list-style-type: none"> <li>• HD: 8 kHz</li> <li>• ND: 2 kHz</li> <li>• HD: 5 kHz</li> <li>• ND: 2 kHz</li> <li>• HD: 2 kHz</li> <li>• ND: 2 kHz</li> </ul>												
Max. output voltage			• Proportional to input voltage: 380-480 V												
Max. output frequency			<ul style="list-style-type: none"> <li>• AOLV, EZOLV: 120 Hz</li> <li>• CL-V/f, CLV, AOLV/PM, CLV/PM: 400 Hz</li> <li>• V/f, OLV, OLV/PM: 590 Hz</li> </ul>												
Rated voltage and frequency			<ul style="list-style-type: none"> <li>• 3-phase AC power supply 380-480 V at 50/60 Hz</li> <li>• DC power supply 513-679 VDC</li> </ul>												
Allowable voltage fluctuation			-15% to +10%												
Allowable frequency fluctuation			±5%												
Power supply	Input Power (kVA)	< 460 V	HD	57	69	84	113	136	165	198	239	297	327	370	465
			ND	69	84	113	136	165	198	239	297	327	370	465	523
	≥ 460 V	HD	49	59	72	98	117	142	193	240	288	335	382	429	
		ND	73	88	120	143	174	236	295	352	410	468	526	584	
Weight (kg)			22	25	38	39	71			122	126	198		207	

- \*1. The maximum applicable motor output complies with 380 V motor ratings as specified in Annex G of IEC 60947-4-1. The rated output current of the drive output amps must be equal to or more than the motor rated current.
- \*2. The maximum applicable motor output complies with 460 V motor ratings as specified in NEC Table 430.250. The rated output current of the drive output amps must be equal to or more than the motor rated current.
- \*3. The rated output capacity is calculated with a rated output voltage of 380 V.
- \*4. The rated output capacity is calculated with a rated output voltage of 460 V.
- \*5. Derating may be necessary for applications that start and stop frequently.
- \*6. Derate the drive capacity to use values to 15 kHz maximum (4002 to 4103 models), 10 kHz maximum (4140 to 4389 models) or 5 kHz maximum (4453 to 4675 models).

Common specifications

Model number Q2A-A□	Specifications
Control methods	V/f Control (V/f), Closed Loop V/f Control (CL-V/f), Open Loop Vector Control (OLV), Closed Loop Vector Control (CLV), Advanced Open Loop Vector Control (AOLV), Open Loop Vector Control for PM (OLV/PM), Advanced Open Loop Vector Control for PM (AOLV/PM), Closed Loop Vector Control for PM (CLV/PM), EZ Open Loop Vector Control (EZOLV)
Frequency control range	<ul style="list-style-type: none"> <li>• AOLV, EZOLV: 0.01 to 120 Hz</li> <li>• CL-V/f, CLV, AOLV/PM, CLV/PM: 0.01 to 400 Hz</li> <li>• V/f, OLV, OLV/PM: 0.01 to 590 Hz</li> </ul>
Frequency tolerance	<ul style="list-style-type: none"> <li>• Digital inputs: ±0.01% of the max. output frequency (-10 to +40 °C)</li> <li>• Analog inputs: ±0.1% of the max. output frequency (25 ±10 °C)</li> </ul>
Frequency setting resolution	<ul style="list-style-type: none"> <li>• Digital inputs: 0.01 Hz</li> <li>• Analog inputs: 1/2048 of the max. output frequency (11-bit signed)</li> </ul>
Output frequency resolution	0.001 Hz
Frequency setting signal	<ul style="list-style-type: none"> <li>• Main speed freq reference: -10 to +10 VDC (20 kΩ), 0 to 10 VDC (20 kΩ), 4 to 20 mA (250 Ω), 0 to 20 mA (250 Ω)</li> <li>• Main speed reference: Pulse train input (max. 32 kHz)</li> </ul>
Starting torque <sup>*1</sup>	<ul style="list-style-type: none"> <li>• V/f, CL-V/f: 150%/3Hz</li> <li>• OLV, AOLV: 200%/0.3Hz</li> <li>• CLV, AOLV/PM, CLV/PM: 200%/0 rpm (rev/min)</li> <li>• OLV/PM: 100%/5% speed</li> <li>• EZOLV: 100%/1% speed</li> </ul>
Speed control range	<ul style="list-style-type: none"> <li>• V/f, CL-V/f: 1:40</li> <li>• OLV, AOLV: 1:200</li> <li>• CLV, CLV/PM: 1:1500</li> <li>• OLV/PM: 1:20</li> <li>• AOLV/PM: 1:100 (when high frequency injection is enabled)</li> <li>• EZOLV: 1:100</li> </ul>
Zero speed control	Possible in these control methods: CLV, AOLV/PM, CLV/PM
Torque limits	Parameter settings allow different limits in four quadrants in these control methods: OLV, CLV, AOLV, AOLV/PM, CLV/PM, EZOLV
Accel/Decel Time	0.0 to 6000.0 s (the drive can set four pairs of different acceleration and deceleration times)

Control functions	Braking torque	Approximately 20% Approximately 125% with a dynamic braking option Short-time average deceleration torque: <ul style="list-style-type: none"> <li>Motor output 0.4/0.75 kW: over 100%</li> <li>Motor output 1.5 kW: over 50%</li> <li>Motor output 2.2 kW or higher: over 20%, over-excitation braking/high slip braking allow for approximately 40%</li> </ul> Continuous regenerative torque: approx. 20%, dynamic braking option allows for approximately 125%, 10% ED, 10 s <sup>-2</sup> Models 2004 to 2138 and 4002 to 4168 have a built-in braking transistor. Short-time average deceleration torque refers to the torque needed to decelerate the motor (uncoupled from the load) from the rated speed to zero. Motor characteristics can change the actual specifications. Motor characteristics change the continuous regenerative torque and short-time average deceleration torque for motors of 2.2 kW or higher.
	V/f characteristics	Select from 15 pre-defined V/f patterns or a user-set V/f pattern
Functionality	Main control functions	Torque control, Droop control, Speed/Torque control switching, Feed forward control, Zero servo function, Restart after momentary power loss, Speed search, Overtorque/Undertorque detection, Torque limit, 17 step speed (max), Accel/Decel switch, S-curve acceleration/deceleration, 3-wire sequence, Auto-tuning (rotational and stationary), Dwell function, Cooling fan ON/OFF, Slip compensation, Torque compensation, Frequency Jump, Upper/lower limits for frequency reference, DC injection braking at start and stop, Overexcitation braking, High slip braking, PID control (with sleep function), Energy saving control, MEMOBUS/Modbus communication (RS-485 max. 115.2 kbps), Auto restart, Application presets, Q2dev (customized functions), Removable terminal block with parameter backup function, Online tuning, KEB, Overexcitation deceleration, Inertia (ASR) tuning, Overvoltage suppression, High frequency injection
Protection functions	Motor	Electronic thermal overload protection
	Momentary overcurrent	Drive stops when the output current exceeds 200% of the HD output current
	Overload	Drive stops when the output current exceeds 150% of the HD output current or 110% of the ND output current for 60 seconds <sup>*3</sup>
	Overvoltage	200 V class: Stops when the DC bus voltage is more than approximately 410 V 400 V class: Stops when the DC bus voltage is more than approximately 820 V
	Undervoltage	200 V class: Stops when the DC bus voltage decreases to less than approximately 190 V 400 V class: Stops when the DC bus voltage decreases to less than approximately 380 V
	Momentary power loss ride-thru	Stops when power loss is longer than 15 ms. Continues operation if power loss is shorter than 2 s (depending on parameter settings). Stop time may be shortened depending on the load and motor speed. Drive capacity will change the continuous operation time. A momentary power loss recovery unit is necessary to continue operation through a 2 s power loss on models 2004 to 2056 and 4002 to 4031.
	Heatsink overheat	Protected by thermistor
	Stall prevention	Stall prevention is available during acceleration, deceleration and during run
	Ground fault	Electronic circuit protection This protection detects ground faults during run. The drive will not provide protection when there is a low-resistance ground fault for the motor cable or terminal block or energizing the drive when there is a ground fault.
DC Bus charge LED	Charge LED illuminates when DC bus voltage is more than 50 V.	
Environment	Area of use	Indoor (no corrosive gas, dust, etc...)
	Power supply	Overvoltage Category III
	Ambient temperature	-10°C to +50°C
	Humidity	95% RH or less (without condensation)
	Storage temperature	-20°C to +70°C (short-term temperature during transportation)
	Surrounding area	Pollution degree 2 or less Install the drive in an area without: <ul style="list-style-type: none"> <li>Oil mist, corrosive or flammable gas or dust</li> <li>Metal powder, oil, water or other unwanted materials</li> <li>Radioactive materials or flammable materials, including wood</li> <li>Harmful gas or fluids</li> <li>Salt</li> <li>Direct sunlight</li> </ul>
	Altitude	Up to 1000 meters max. (output derating of 1% per 100 m above 1000 m, max. 3000 m)
	Vibration	<ul style="list-style-type: none"> <li>10 Hz to 20 Hz: 1G (9.8 m/s<sup>2</sup>)</li> <li>20 Hz to 55 Hz: 2004 to 2211 and 4002 to 4168 - 0.6G (5.9 m/s<sup>2</sup>) / 2257 to 2415 and 4208 to 4675 - 0.2G (2 m/s<sup>2</sup>)</li> </ul>
Installation orientation	Install the drive vertically for sufficient airflow to cool the drive.	
Safety standard	<ul style="list-style-type: none"> <li>UL61800-5-1</li> <li>EN61800-3</li> <li>IEC/EN61800-5-1</li> <li>Two Safe Disable inputs and one EDM output according to ISO/EN13849-1 Cat.III PLe, IEC/EN61508 SIL3</li> </ul>	
Protection design <sup>*4</sup>	Open chassis type: IP20	

\*1. Correctly select drive capacity for this starting torque in these control methods: OLV, CLV, AOLV, AOLV/PM, CLV/PM.

\*2. Set L3-04 to 0 (Stall Prevention during Decel = Disabled) when operating the drive with a regenerative converter, regenerative unit, braking resistor or braking resistor unit. Failure to obey could prevent the drive from stopping in the specified deceleration time and cause serious injury or death.

\*3. The drive can trigger the overload protection function within the overload tolerance if the output frequency is less than 6 Hz. Do not allow the overload more than once every ten minutes.

\*4. Install an UL Type 1 kit on an Open-chassis type (IP20) to convert the drive to a Enclosed wall-mounted type (UL Type 1).

Dimensions

Q2A inverter

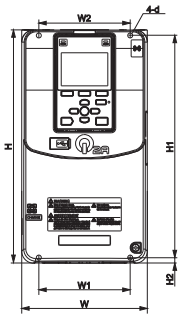

Figure 1

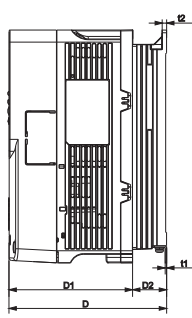

Figure 2

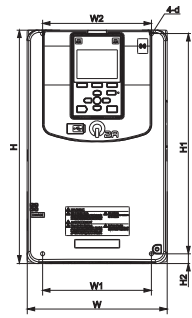

Figure 3

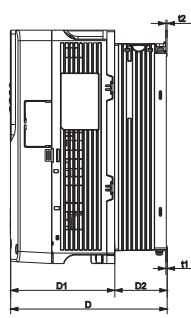

Figure 4

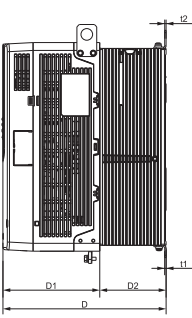

Figure 5

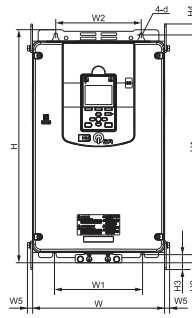

Figure 6

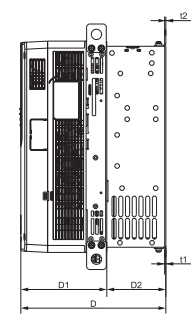

Figure 7

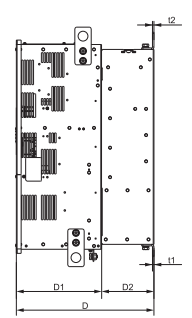

Figure 8

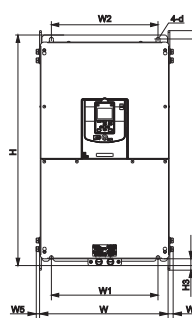
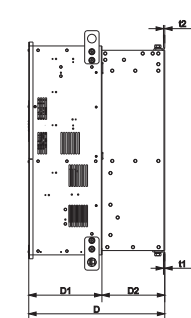

Figure 9



Voltage	Inverter model Q2A-A□	Fig.	Dimensions (mm)														
			W	W1	W2	W5	H	H1	H2	H3	H4	D	D1	D2	t1	t2	d
200 V	2004, 2006, 2010, 2012	1	140	102	102	-	260	248	6	-	-	176	138	38	1.6	5	M5
	2021, 2030, 2042											211		73			
	2056	2	180	140	140		300	284	8			202	134	68		1.6	
	2070, 2082	3	220	192	192		350	335				227	140	87	2.3	2.3	M6
	2110	4	240	195	186	12	400	375	17.5		17.5	280	166	114			
	2138	5	255	170	165		450	424	16	29	21						
	2169, 2211	6	264	190	182		543	516	17.5	28.5	20.5	335	186	149			M8
	2257, 2313	7	312	218	218	18	700	659	28	43.5	28.5	420	260	160	4.5	4.5	M10
2360, 2415	8	440	370	370	20	800	757		44	30	472	254	218			M12	
400 V	4002, 4004, 4005	1	140	102	102	-	260	248	6	-	-	176	138	38	1.6	5	M5
	4007, 4009, 4012, 4018, 4023											211		73			
	4031, 4038	2	180	140	140		300	284	8			202	134	68		1.6	
	4044	3	220	192	192		350	335				227	140	87	2.3	2.3	M6
	4060										246		106				
	4075	4	240	195	186	12	400	375	17.5		17.5	280	166	114			
	4089, 4103	5	255	170	165		450	424	16	29	21						
	4140, 4168	6	264	190	182		543	516	17.5	28.5	20.5	335	186	149			M8
	4208, 4250, 4296	7	312	218	218	18	700	659	28	43.5	28.5	420	260	160	4.5	4.5	M10
4371, 4389	8	440	370	370	20	800	757		44	30	472	254	218			M12	
4453, 4568, 4675	9	510	450	450		1140	1093	25.5	43.5	30.5	480	260	220				

Line filters

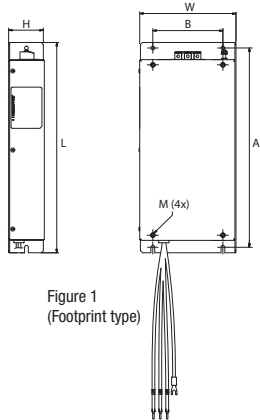

Figure 1  
(Footprint type)

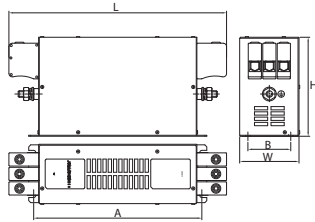

Figure 2  
(Book type)

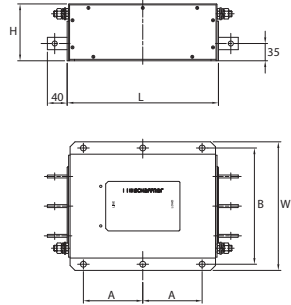
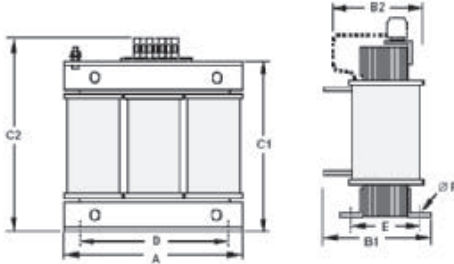

Figure 3  
(Busbar termination type)

Voltage	Reference	Fig.	Dimensions (mm)						Weight (kg)						
			W	H	L	A	B	M							
200 V/400 V	Q2-FIA4010-SE	1	140	52	306	290	102	M5	1.1						
	Q2-FIA4020-SE								1.4						
	Q2-FIA4035-SE								1.8						
	Q2-FIA4050-SE								2.5						
	Q2-FIA4080-SE	2	80	205	250	270	-	M6	4.3						
	Q2-FIA4100-SE								90	150	330	255	65	M10	4.0
	Q2-FIA4170-SE								120	170	452	365	102		6.0
	Q2-FIA4410-SE	3	260	115	306	2 x 120	235	M12	9.5						
Q2-FIA4600-SE	135											11.0			

Input AC Reactor



Voltage	Reference	Dimensions (mm)								Weight (kg)
		A	B1	B2	C1	C2	D	E	F	
200 V	AX-RAI02800100-DE	120	-	70	-	120	80	52	5.5	1.78
	AX-RAI00880200-DE			80				62		2.35
	AX-RAI00350335-DE	180	-	85	-	190	140	55	6	5.5
	AX-RAI00180670-DE			205						6.5
	AX-RAI00091000-DE			105		85	11.7			
	AX-RAI00071550-DE			85						
AX-RAI00042300-DE	120	-	150	-						
400 V	AX-RAI07700042-DE	120	-	70	-	120	80	52	5.5	1.78
	AX-RAI07700050-DE			80				62		2.35
	AX-RAI03500090-DE	180	-	75	-	195	140	55	6	5.5
	AX-RAI01300170-DE			85						190
	AX-RAI00740335-DE			105		205	11.2			
	AX-RAI00360500-DE			110		75	16.0			
	AX-RAI00290780-DE	240	-	110	-	275	200	75	6	11.2
	AX-RAI00191150-DE			110						16.0
	AX-RAI00111850-DE	300	170	-	210	-	-	110	-	25.4
	AX-RAI00072700-DE				110			18.6		
	AX-RAI00043350-DE				140			85		18.6
	AX-RAI00034500-DE				165			110		27.0
	AX-RAI00025350-DE				165			105		27.0
	AX-RAI00025350-DE				260			105		33.5

## DC Reactor

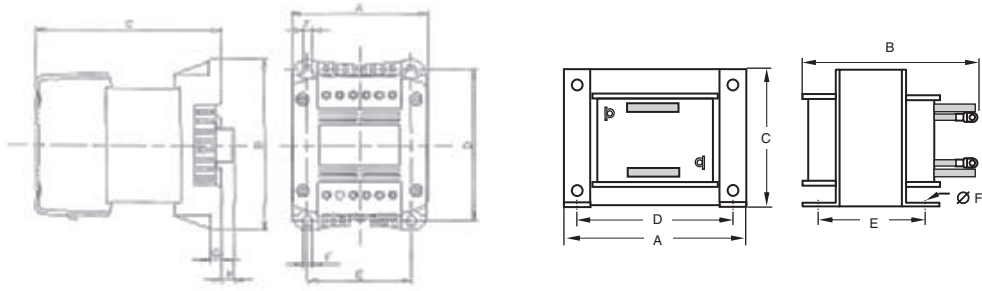
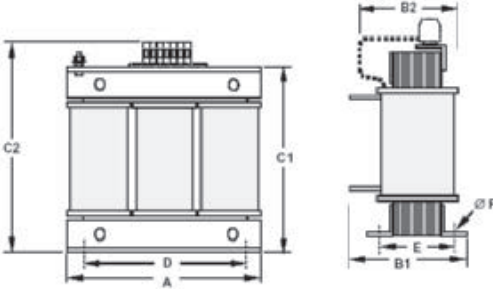

Figure 1

Figure 2

Voltage	Reference	Fig	Dimensions (mm)								Weight (kg)
			A	B	C	D	E	F	G	H	
200 V	AX-RC06750061-DE	1	84	113	105	101	66	5	7.5	2	1.60
	116				1.95						
	AX-RC03510093-DE		108	135	124	120	82	6.5	9.5	9.5	3.20
	120				152						
	AX-RC02510138-DE		150	177	146	160	160	115	2	-	6.00
	183				11.4						
	AX-RC01600223-DE		195	161	160	185	88	10	-	-	14.3
	183	17.0									
AX-RC01110309-DE	2	195	161	163	185	88	10	-	-	17.0	
183				163							185
400 V	AX-RC43000020-DE	1	84	113	96	101	66	5	7.5	2	1.22
	116				1.95						
	AX-RC06400116-DE		108	135	133	120	82	6.5	9.5	9.5	3.70
	120				152						
	AX-RC04410167-DE		150	177	146	160	160	115	2	-	6.00
	183				11.4						
	AX-RC03350219-DE		195	161	160	185	88	10	-	-	14.3
183	160	185			88						
AX-RC02330307-DE	2	195	161	163	185	88	10	-	-	17.0	
183				163							185
AX-RC01750430-DE	2	195	161	163	185	88	10	-	-	17.0	
183				163							185

Output AC Reactor



Voltage	Reference	Dimensions (mm)								Weight (kg)	
		A	B1	B2	C1	C2	D	E	F		
200 V	AX-RAO07600042-DE	120	-	70	-	120	80	52	5.5	1.78	
	AX-RAO04100075-DE			80				62		2.35	
	AX-RAO03000105-DE										
	AX-RAO01830160-DE	180		85		195	140	55	6	5.5	
	AX-RAO01150220-DE									210	6.5
	AX-RAO00950320-DE			95		65		9.1			
	AX-RAO00630430-DE			105		75		11.7			
	AX-RAO00490640-DE	240		110		275	200			16.0	
	AX-RAO00330950-DE					300					
	AX-RAO00251210-DE										
	AX-RAO00191450-DE		130	-	215	-		85		18.6	
	AX-RAO00161820-DE		160					110		27.0	
	AX-RAO00132200-DE		165					125		33.5	
400 V	AX-RAO16300038-DE	120	-	80	-	120	80	62	5.5	2.35	
	AX-RAO11800053-DE										
	AX-RAO07300080-DE	180		85		195	140	55	6	5.5	
	AX-RAO04600110-DE										210
	AX-RAO03600160-DE										
	AX-RAO02500220-DE	240		95		275	200	65		16.0	
	AX-RAO02000320-DE			110				75			
	AX-RAO01650400-DE										
	AX-RAO01300480-DE										
	AX-RAO00800750-DE			120		281		85		18.6	
	AX-RAO00680900-DE			150		110		27.0			
	AX-RAO00531100-DE			125		105		27.9			
	AX-RAO00401490-DE	300	170	-	270	-		125		44.0	
	AX-RAO00331760-DE										
	AX-RAO00262170-DE	360	230		315		300	150	8	55.0	
	AX-RAO00212600-DE	420	240		370					75.0	
	AX-RAO00173250-DE	480	275		400		370	165	10	136.0	
	AX-RAO00134440-DE						400	195		165.0	
AX-RAO00115250-DE							225	215.0			

## Chokes

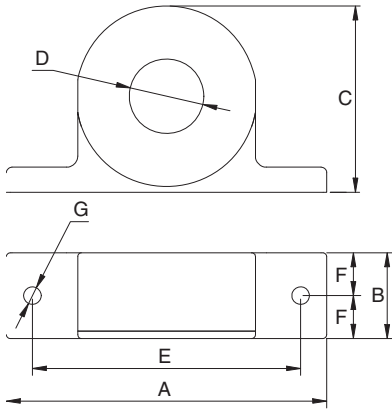

Figure 1

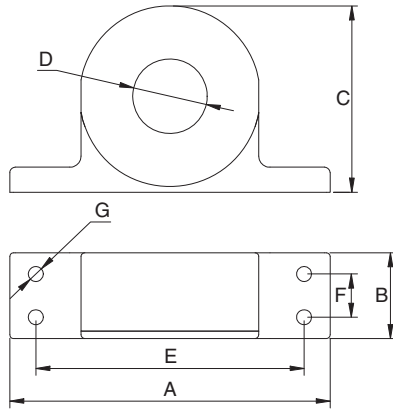

Figure 2

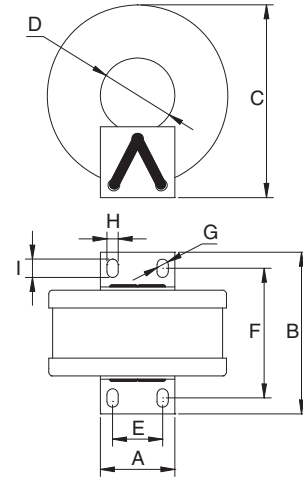
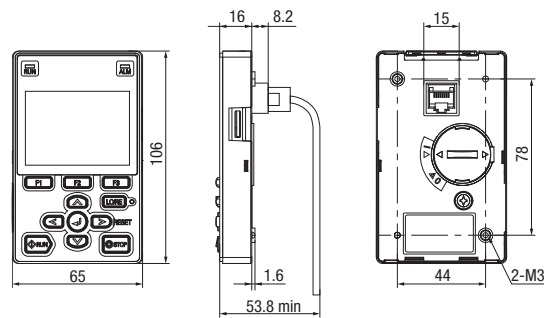

Figure 3

Reference	Fig	D (diameter)	Motor (kW)	Dimensions (mm)								Weight (kg)	
				A	B	C	D	E	F	G (diameter)	H		I
AX-FER2102-PE	1	21	< 2.2	86	24	50	21	70	12	4	-	-	0.09
AX-FER2815-PE		28	< 15	106	25	65	28	90	12.5				0.22
AX-FER5045-PE	2	50	< 45	150	51	112	50	125	30	5	5	7	0.53
AX-FER5255-PE	3	52	≥ 55	47	75.5	110	52	30	58.5				1.20

## LCD keypad



D1000 kit - DC Supply with Regenerative Active Front End

Regenerative DC bus supply unit (D1000)

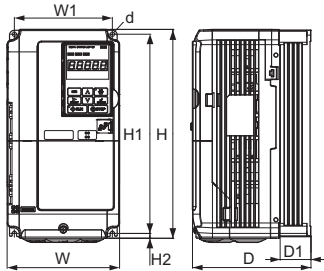

Figure 1

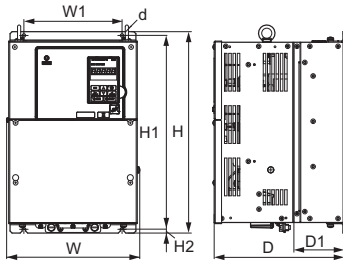

Figure 2

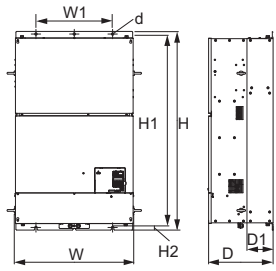

Figure 3

Voltage class	Model CIMR-DC□	Fig.	Protection class	Dimensions (mm)								Weight (kg)	
				W	H	D	W1	H1	H2	D1	d		
400 V	4A0005	1	IP20	180	300	187	160	284	8	75	M5	5	
	4A0010			220	365	197	192	335		78		8	
	4A0020	2	IP00	275	450	258	220	435	7.5	100	M6	21	
	4A0040			325	550	283	260	535		110		34	
	4A0060	3	IP00	500	800	350	370	773	13	130	M12	36	
	4A0100			370	1140	370	440	1100		15		150	85
	4A0130			370	1140	370	440	1100		15		150	183
	4A0185												194
	4A0270												
4A0370													

EMC filter

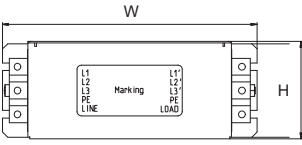

Figure 1

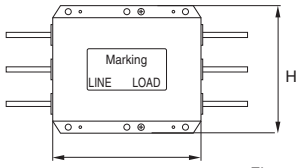
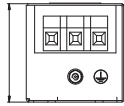

Figure 2

Reference	Fig.	Dimensions (mm)			Weight (kg)
		W	H	D	
B84143A0020R106	1	386	200	202	0.6
B84143A0035R106		426	250	322	0.9
B84143A0065R106		436	310	432	1.9
B84143B0180S080	2	200	170	110	5.0
B84143B0400S080		290	190	116	7.5
B84143B1000S080		300	260	140	18.5

## Low harmonic filter

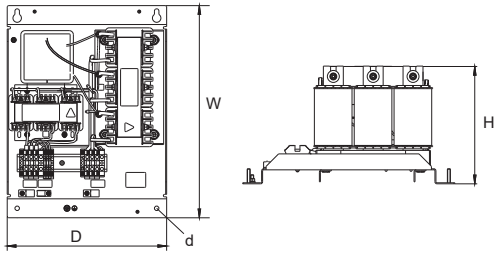

Figure 1

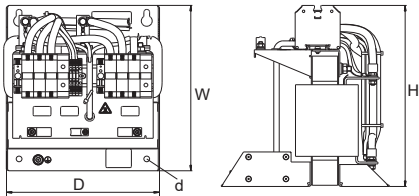

Figure 2a

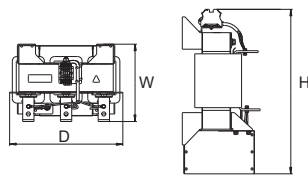

Figure 3a

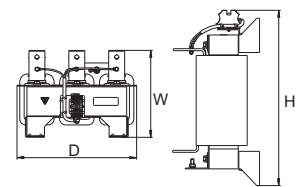

Figure 4a

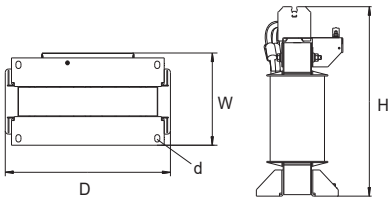

Figure 2b

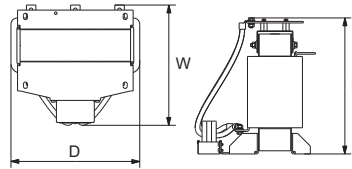

Figure 3b

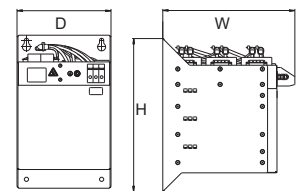

Figure 4b

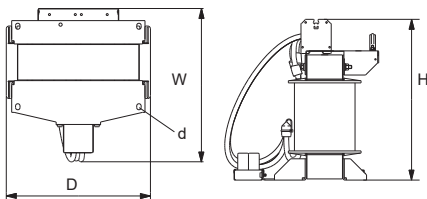

Figure 2c

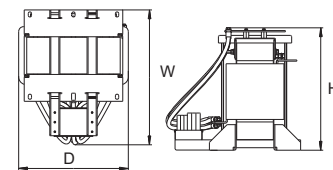

Figure 3c

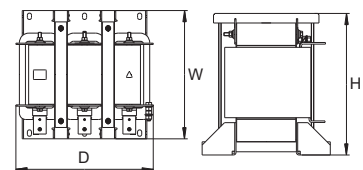

Figure 4c

Reference	Component	Fig.	Dimensions (mm)				Weight (kg)
			W	H	D	d (diameter)	
B84143G0008R176		1	386	176 ±5	200	9	9
B84143G0016R176			426	234 ±5	320		18
B84143G0030R176				236 ±5			28
B84143G0043R176			436	286 ±5	430		37
B84143G0058R176							64
B84143G0086R176	Harmonic filter	2a	265	288 ±5	240	9	20
	10% choke	2b	149	max. 390	300	15 x 25	55
B84143G0145R176	Harmonic filter	2a	328	303 ±5	240	9	30
	10% choke	2c	max. 390	max. 405	max. 365	15 x 25	69
B84143G0210S176	Harmonic filter	3a	206 ±3	438	300	-	39
	10% choke	3b	max. 400	max. 445	max. 420	-	98
B84143G0300S176	Harmonic filter	3a	216 ±3	437	300	-	42
	10% choke	3c	max. 550	max. 490	max. 440	-	149
B84143G0410S176	3% choke	4a	218 ±3	440 ±2.5	300	-	45
	Capacitor	4b	281	327	200	-	12
	10% choke	4c	401	max. 450	430	-	163
B84143G0560S176	3% choke	4a	243 ±3	430 ±2.5	300	-	55
	Capacitor	4b	409	379	307	-	25
	10% choke	4c	351 ±3	max. 590	max. 520	-	175

R1000 kit - Regenerative Braking unit

Regenerative Braking unit (R1000)

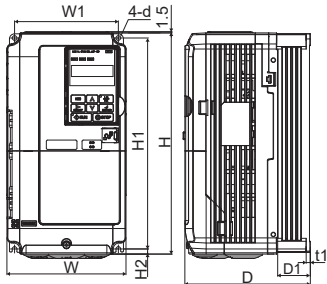

Figure 1

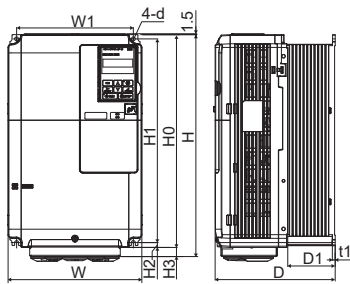

Figure 2

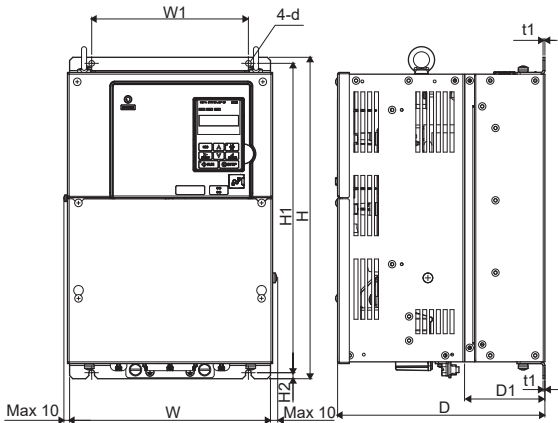

Figure 3

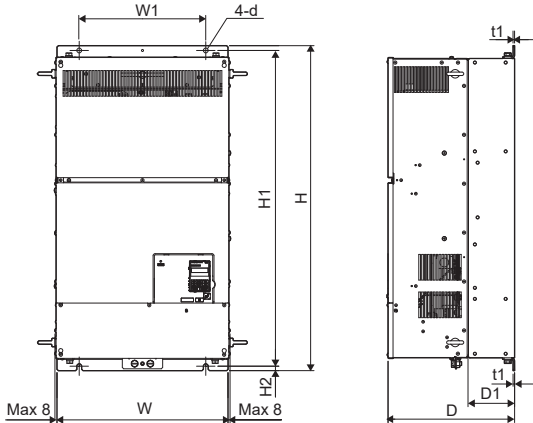

Figure 4

Voltage class	Model CIMR-RC□	Fig.	Protection class	Dimensions (mm)											Weight (kg)	
				W	H	D	W1	H0	H1	H2	H3	D1	t1	d		
400 V	4A03P5	1	IP20	140	260	167	122	-	248	6	-	55	5	M5	4	
	4A0005			180	300	187	160	-	284	8	-	75	-	-	-	-
	4A0007															
	4A0010															
	4A0014	2		220	365	197	192	350	355	15	78	M6	8			
	4A0017															
	4A0020															
	4A0028															
	4A0035	3		IP00	275	450	258	220	-	435	7.5	-	100	2.3	M6	20
	4A0043				325	550	283	260	-	535	-	-	110	-	-	-
	4A0053															
	4A0073	4			450	705	330	325	-	680	13	-	130	3.2	M10	62
4A0105	500		800		350	370	-	773	-	-	-	4.5	M12	86		
4A0150														87		
4A0210																
4A0310																

Current suppression reactor

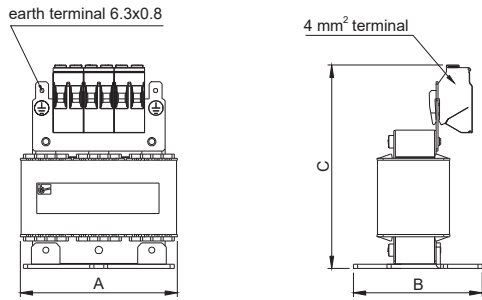

Figure 1

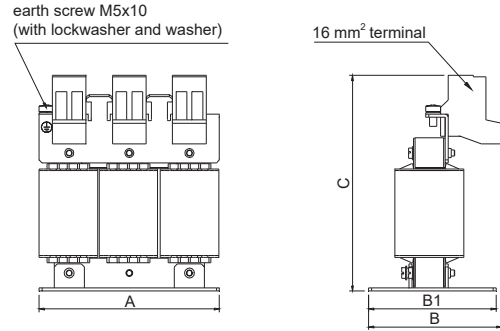

Figure 2

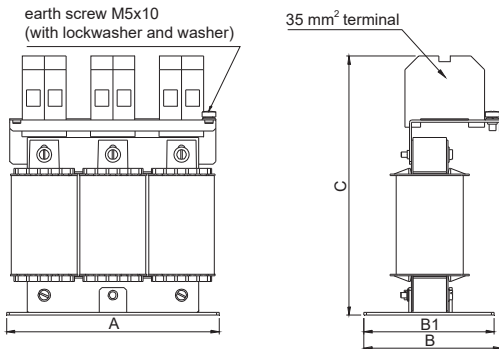

Figure 3

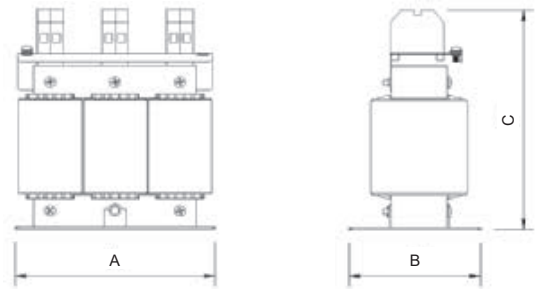

Figure 4

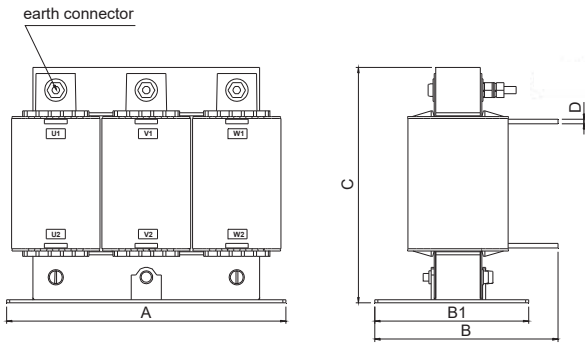

Figure 5

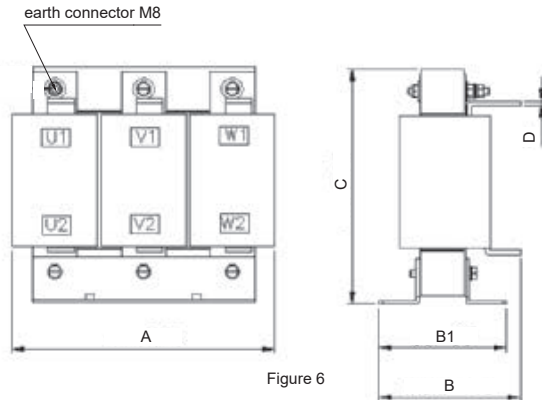

Figure 6

Reference	Fig.	Dimensions (mm)					Weight (kg)
		A	B	B1	C	D	
B1509105	1	max. 78	63	-	102	-	0.85
B1509106		max. 96	60	-	118	-	1.31
B1509107		-	-	-	-	-	1.32
B1509108	2	120	max. 90	85	150	-	1.9
B1509109		-	-	-	-	-	1.93
B1509110	3	155	max. 102	95	195	-	3.8
B1504118	4	155	95	-	175	-	4.0
B1509111	3	155	max. 102	95	195	-	4.43
B1509112		-	-	110	-	-	5.95
B1509113	5	185	max. 125	102	160	3	6.9
B1509114		-	-	max. 140	122	-	10.8
B1505002	6	220	max. 115	90	205	4	17.0
B1505008		230	max. 140	107	215	5	22.0
B1505011		240	max. 150	120	235	-	29.0

**Braking unit**

Fig 1

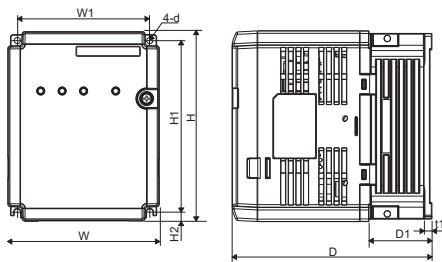
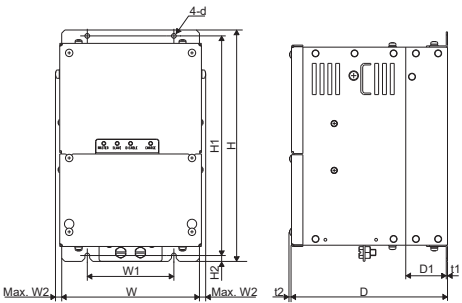

Fig 2



Voltage	Type	Fig.	Protection class	Dimensions (mm)											Weight (kg)
				W	W1	W2	H	H1	H2	D	D1	t1	t2	d	
200 V	CDBR-2022D	1	IP20	120	105	–	150	136	7	157	48	6	–	M4	2.0
	CDBR-2037D														
	CDBR-2110D	2	IP00	175	110	7.9	294	279	7.5	200	53.5	1.6	2.5	M5	7.5
400 V	CDBR-4045D	1	IP20	120	105	–	150	136	7	157	48	6	–	M4	2.0
	CDBR-4220D	2	IP00	175	110	7.9	294	279	7.5	200	53.5	1.6	2.5	M5	7.5

**Resistor**

AX-REM00K1200-IE

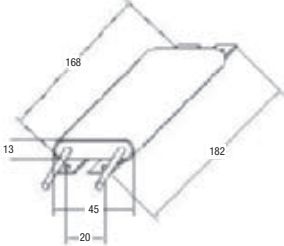

Fig 1

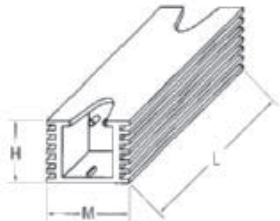

Fig 2

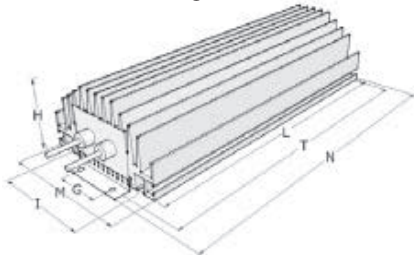

Fig 3

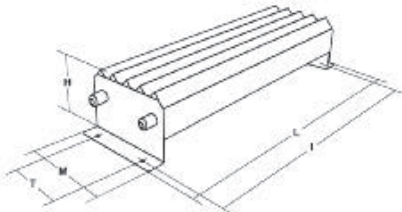

Fig 4

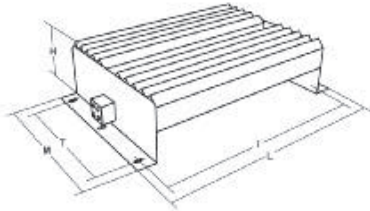
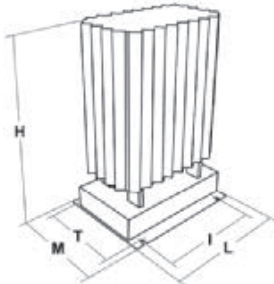

Fig 5



Type	Fig	Dimensions (mm)							Weight (kg)
		L	H	M	I	T	G	N	
AX-REM00K1400-IE	1	105	27	36	94	–	–	–	0.2
AX-REM00K2200-IE		200			189				
AX-REM00K4035-IE					249				
AX-REM00K4075-IE					309				
AX-REM00K5120-IE		260			61				
AX-REM00K6035-IE	320	61	100	74.5	216	40	230	0.73	
AX-REM00K9020-IE	2	200	61	100	74.5	216	40	230	1.41
AX-REM00K9070-IE	3	365	73	105	350	70	–	–	4
AX-REM01K9070-IE									
AX-REM02K1017-IE	4	310	100	240	295	210	–	–	7
AX-REM03K5010-IE		365							8
AX-REM03K5035-IE	5	206	350	140	190	50	–	–	8.1
AX-REM19K0006-IE									
AX-REM19K0008-IE									
AX-REM19K0020-IE									
AX-REM19K0030-IE									
AX-REM38K0012-IE	306	290	14.5						

Installation

Standard connections

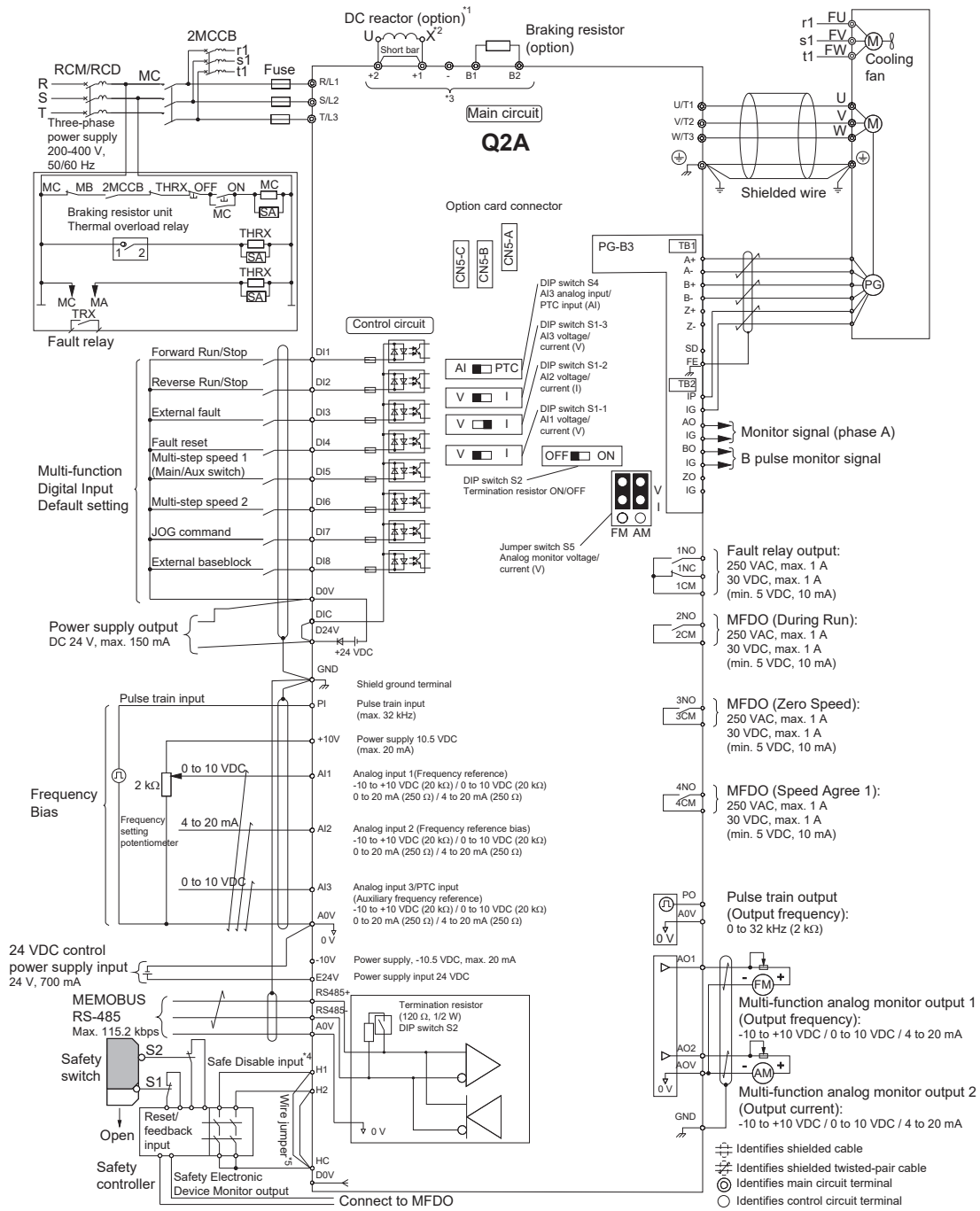

- \*1. When you install a DC reactor, you must remove the jumper between terminals +1 and +2.
- \*2. Models 2110 to 2415 and 4060 to 4675 have a DC reactor.
- \*3. Connect peripheral options to terminals -, +1, +2, B1 and B2.
- \*4. Use only SOURCE Mode for Safe Disable input.
- \*5. Disconnect the wire jumper between H1 and HC, and H2 and HC to use the Safe Disable input.

Main circuit

Terminal	Name	Function
R/L1, S/L2, T/L3	Main circuit power supply input	Used to connect a power supply
U/T1, V/T2, W/T3	Inverter output	Used to connect a motor
B1, B2	Braking resistor connection (2004 to 2138 and 4002 to 4168)	To connect a braking resistor or braking resistor unit
+2	DC reactor connection (2004 to 2082 and 4002 to 4044 models)	To connect peripheral devices like DC power input, braking unit or DC reactor
+1	DC power supply input	
-	Braking unit connection (2169 to 2415 and 4208 to 4675 models)	
+3		
	<ul style="list-style-type: none"> <li>200 V class: D class grounding (ground to 100 Ω or less)</li> <li>400 V class: C class grounding (ground to 10 Ω or less)</li> </ul>	To ground the inverter

Control circuit

Type	Terminal	Name	Function (Signal level)
Digital input signals	DI1	MFDI selection 1 (ON: Forward run, OFF: Stop)	Photocoupler 24 V, 6 mA  Install the wire jumpers between DIC-D24V and DIC-D0V terminals to set the MFDI power supply. <ul style="list-style-type: none"> <li><b>SINK mode:</b> Install a jumper between SC and SP terminals.</li> <li><b>SOURCE mode:</b> Install a jumper between SC and SN terminals.</li> <li><b>External power supply:</b> No jumper necessary.</li> </ul>
	DI2	MFDI selection 2 (ON: Reverse run, OFF: Stop)	
	DI3	MFDI selection 3 (External fault (N.O.))	
	DI4	MFDI selection 4 (Fault reset)	
	DI5	MFDI selection 5 (Multi-step speed reference 1)	
	DI6	MFDI selection 6 (Multi-step speed reference 2)	
	DI7	MFDI selection 7 (Jog command)	
	DI8	MFDI selection 8 (Baseblock command (N.O.))	
	D0V <sup>*1</sup>	MFDI power supply 0 V	
	DIC	MFDI selection common	
D24V1	MFDI power supply +24 VDC		
Safe Disable input	H1	Safe Disable input 1	Remove the jumper between H1-HC and H2-HC terminals to use the Safe Disable input. 24 V, 6 mA ON: Normal operation, OFF: Coasting motor Internal impedance: 4.7 kΩ Minimum OFF time of 2 ms
	H2	Safe Disable input 2	
	HC <sup>*2</sup>	Safe Disable function common	
Master frequency reference	PI	Pulse train input	Response frequency: 0 to 32 kHz H level duty and voltage: 30 to 70%, 3.5 to 13.2 V L level voltage: 0 to 0.8 V Input impedance: 3 kΩ
	+10V	Power supply for frequency setting	+10.5 V (allowable current max. 20 mA)
	-10V		-10.5 V (allowable current max. 20 mA)
	AI1	MFAI1 (Frequency reference)	<ul style="list-style-type: none"> <li>Voltage input or current input: -10 V to + 10 V / -100 to +100 % 0 to 10 V / 100 % (input impedance: 20 kΩ) 4 to 20 mA / 100 %, 0 to 20 mA / 100 % (input impedance: 250 Ω)</li> </ul>
	AI2	MFAI2 (Frequency reference bias)	
	AI3	MFAI3/PTC input (Auxiliary frequency reference)	<ul style="list-style-type: none"> <li>Voltage input or current input: -10 V to + 10 V / -100 to +100 % 0 to 10 V / 100 % (input impedance: 20 kΩ) 4 to 20 mA / 100 %, 0 to 20 mA / 100 % (input impedance: 250 Ω)</li> <li>PTC input (Motor overheat protection)</li> </ul>
	A0V	Frequency reference common	0 V
GND	Connecting shielded cable		

Type	Terminal	Name	Function (Signal level)
Fault relay output	1NO	N.O. output	Relay output 30 VDC, 10 mA to 1 A 250 VAC, 10 mA to 1 A Min. load: 5 V, 10 mA (Reference value)
	1NC	N.C. output	
	1CM	Digital output common	
MFDO <sup>3</sup>	2NO	MFDO (During Run)	Relay output 30 VDC, 10 mA to 1 A 250 VAC, 10 mA to 1 A Min. load: 5 V, 10 mA (Reference value)
	2CM		
	3NO	MFDO (Zero Speed)	
	3CM		
	4NO	MFDO (Speed Agree 1)	
Monitor output	PO	Pulse train output (Output frequency)	32 kHz max.
	A01	MFAO1 (Output frequency)	Select voltage or current output: 0 to 10 V / 0 to 100 % -10 to 10 V / -100 to 100 %
	A02	MFAO2 (Output current)	4 to 20 mA
	A0V	Monitor common	0 V
External power supply input	E24V	External 24 V power supply input	Supplies backup power to the drive control circuit, keypad and option board. 21.6 to 26.4 VDC, 700 mA
	A0V	External 24 V power supply ground	0 V
MEMOBUS/Modbus <sup>4</sup>	RS485+	Communication input/output (+)	MEMOBUS/Modbus communication protocol Use an RS-485 cable to connect the inverter Maximum 115.2 kbps
	RS485-	Communication output (-)	
	A0V	Shield ground	0 V

- \*1. Do not close the circuit between D24V and D0V terminals. Failure to obey will cause damage to the drive.
- \*2. Do not close the circuit between HC and D0V terminals. Failure to obey will cause damage to the drive.
- \*3. Do not set functions that frequently switch ON/OFF to MFDO because this will decrease the performance life of the relay contacts.
- \*4. Select DIP switch S2 to ON to enable the termination resistor in the last drive in a MEMOBUS/Modbus network.

Side by side mounting

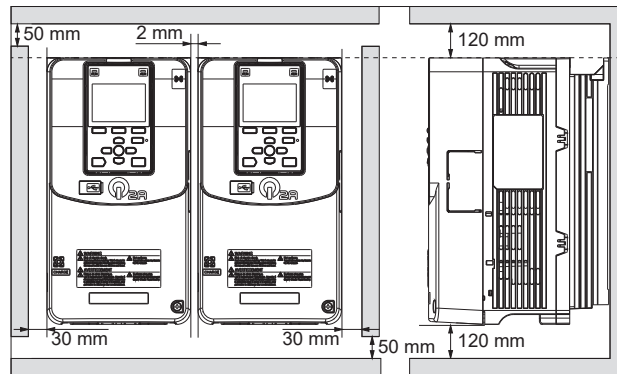

Inverter watt loss

200 V class

Inverter model Q2A-A□	Heavy Duty (HD)					Normal Duty (ND)					
	Rated output current (A)	Carrier frequency (kHz)	Interior unit loss (W)	Cooling fin loss (W)	Total loss (W)	Rated output current (A)	Carrier frequency (kHz)	Interior unit loss (W)	Cooling fin loss (W)	Total loss (W)	
2004	3.2	8	35	18	53	3.5	2	35	16	51	
2006	5		37	26	63	6		38	25	63	
2010	8		44	43	87	9.6		49	46	95	
2012	11		50	61	111	12.2		56	62	118	
2021	17.5		56	105	161	21		75	125	200	
2030	25		74	174	248	30		95	206	301	
2042	33		88	183	271	42		129	227	356	
2056	47		112	267	379	56		149	302	451	
2070	60		145	373	518	70		177	403	580	
2082	75		179	478	657	82		202	467	669	
2110	88		155	563	718	110		192	631	823	
2138	115		212	680	892	138		269	814	1083	
2169	145		5	275	820	1095		169	338	941	1279
2211	180			314	991	1305		211	384	1131	1515
2257	215	398		1252	1650	257	519	1534	2053		
2313	283	502		1643	2145	313	579	1794	2373		
2360	346	582		1978	2560	360	655	2071	2726		
2415	415	644		2359	3003		-				

400 V class

Inverter model Q2A-A□	Heavy Duty (HD) < 460 V					Heavy Duty (HD) ≥ 460 V				
	Rated output current (A)	Carrier frequency (kHz)	Interior unit loss (W)	Cooling fin loss (W)	Total loss (W)	Rated output current (A)	Carrier frequency (kHz)	Interior unit loss (W)	Cooling fin loss (W)	Total loss (W)
4002	1.8	8	38	15	53	1.6	8	38	15	53
4004	3.4		42	28	70	2.1		39	19	58
4005	4.8		46	37	83	3.4		43	30	73
4007	5.5		48	45	93	4.8		46	43	89
4009	7.2		37	61	98	6.9		35	63	98
4012	9.2		46	82	128	7.6		39	71	110
4018	14.8		65	140	205	11		53	110	163
4023	18		73	150	223	14		59	120	179
4031	24		101	211	312	21		85	192	277
4038	31		119	272	391	27		99	245	344
4044	39		148	354	502	34		124	320	444
4060	45		126	389	515	40		115	361	476
4075	60		165	389	515	52		147	477	624
4089	75		184	617	801	65		165	566	731
4103	91	237	779	1016	77	206	700	906		
4140	112	5	300	956	1256	96	5	265	849	1114
4168	150		486	1274	1760	124		400	1073	1473
4208	180		446	1432	1878	156		405	1300	1705
4250	216		558	1464	2022	180		454	1174	1628
4296	260		692	2061	2753	240		664	2021	2685
4371	304		824	2346	3170	302		843	2499	3342
4389	371		777	2212	2989	361		745	2161	2906
4453	414		2	963	2696	3659		414	2	1024
4568	453	1086		3035	4121	477	1183	3329		4512
4675	605	1328		3995	5323		-			

Inverter model Q2A-A□	Normal Duty (ND) < 460 V					Normal Duty (ND) ≥ 460 V				
	Rated output current (A)	Carrier frequency (kHz)	Interior unit loss (W)	Cooling fin loss (W)	Total loss (W)	Rated output current (A)	Carrier frequency (kHz)	Interior unit loss (W)	Cooling fin loss (W)	Total loss (W)
4002	2.1	2	39	16	55	2.1	2	39	16	55
4004	4.1		44	33	77	3		42	25	67
4005	5.4		48	31	79	4.8		45	28	73
4007	7.1		52	44	96	6.9		50	42	92
4009	8.9		42	58	100	7.6		35	49	84
4012	11.9		57	84	141	11		49	76	125
4018	17.5		82	144	226	14		64	112	176
4023	23.4		108	185	293	21		87	158	245
4031	31		138	222	360	27		109	188	297
4038	38		145	270	415	34		116	234	350
4044	44		168	335	503	40		137	296	433
4060	59.6		157	444	601	52		133	379	512
4075	74.9		185	527	712	65		156	450	606
4089	89.2		212	665	877	77		180	569	749
4103	103		264	766	1030	96		229	698	927
4140	140		393	1126	1519	124		334	982	1316
4168	168		574	1348	1922	156		481	1199	1680
4208	208		493	1465	1958	180		429	1275	1704
4250	250		686	1738	2424	240		648	1643	2291
4296	296		805	2155	2960	302		817	2257	3074
4371	371	1022	2553	3575	361	975	2561	3536		
4389	389	867	2393	3260	414	873	2422	3295		
4453	453	1086	3035	4121	477	1183	3329	4512		
4568	568	1429	3989	5418	515	1320	3697	5017		
4675	675	1526	4572	6098	-	-	-	-		

Input AC reactor

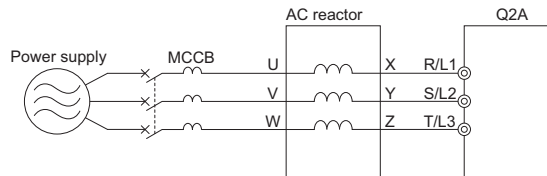

200 V class				400 V class			
Max. applicable motor output (kW) <sup>*1</sup>	Reference	Current value (A)	Inductance (mH)	Max. applicable motor output (kW) <sup>*1</sup>	Reference	Current value (A)	Inductance (mH)
0.55 to 1.5	AX-RAI02800100-DE	8.0	2.8	0.55	AX-RAI07700042-DE	4.2	7.7
2.2 to 3.0	AX-RAI00880200-DE	20.0	0.88	0.75	AX-RAI07700050-DE	5.0	7.7
4.0 to 7.5	AX-RAI00350335-DE	33.5	0.35	1.5	AX-RAI03500090-DE	9.0	3.5
11.0 to 15.0	AX-RAI00180670-DE	67.0	0.18	2.2	AX-RAI03500100-DE	10.0	3.5
18.5 to 22.0	AX-RAI00091000-DE	100.0	0.09	3.0 to 3.7	AX-RAI01300170-DE	17.0	1.3
30.0 to 37.0	AX-RAI00071550-DE	155.0	0.07	5.5 to 11.0	AX-RAI00740335-DE	33.5	0.74
45.0 to 55.0	AX-RAI00042300-DE	230.0	0.04	15.0 to 18.5	AX-RAI00360500-DE	50.0	0.36
-	-	-	-	22.0 to 30.0	AX-RAI00290780-DE	78.0	0.29
-	-	-	-	37.0 to 45.0	AX-RAI00191150-DE	115.0	0.19
-	-	-	-	55.0 to 75.0	AX-RAI00111850-DE	185.0	0.11
-	-	-	-	90.0 to 110.0	AX-RAI00072700-DE	270.0	0.07
-	-	-	-	150.0	AX-RAI00043350-DE	335.0	0.04
-	-	-	-	185.0 to 220.0	AX-RAI00034500-DE	450.0	0.03
-	-	-	-	260.0	AX-RAI00025350-DE	535.0	0.025

\*1. The motor sizes are for heavy duty applications.

DC reactor

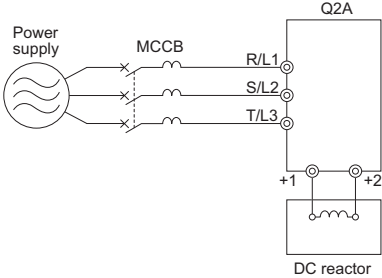

200 V class				400 V class			
Max. applicable motor output (kW) <sup>*1</sup>	Reference	Current value (A)	Inductance (mH)	Max. applicable motor output (kW) <sup>*1</sup>	Reference	Current value (A)	Inductance (mH)
0.55 to 0.75	AX-RC06750061-DE	6.1	6.75	0.55 to 0.75	AX-RC43000020-DE	2.0	43.0
1.5	AX-RC03510093-DE	9.3	3.51	1.5	AX-RC10100069-DE	6.9	10.1
2.2	AX-RC02510138-DE	13.8	2.51	2.2 to 3.0	AX-RC06400116-DE	11.6	6.4
3.0	AX-RC01600223-DE	22.3	1.60	3.7	AX-RC04410167-DE	16.7	4.41
4.0 to 5.5	AX-RC01110309-DE	30.9	1.11	5.5	AX-RC03350219-DE	21.9	3.35
7.5	AX-RC00840437-DE	43.7	0.84	7.5	AX-RC02330307-DE	30.7	2.33
11.0	AX-RC00590614-DE	61.4	0.59	11.0 to 15.0	AX-RC01750430-DE	43.0	1.75
15.0	AX-RC00440859-DE	85.9	0.44	18.5	AX-RC01200644-DE	64.4	1.20
18.5	AX-RC00301275-DE	127.5	0.30		-		

\*1. The motor sizes are for heavy duty applications.

Output AC reactor

200 V class				400 V class			
Max. applicable motor output (kW) <sup>*1</sup>	Reference	Current value (A)	Inductance (mH)	Max. applicable motor output (kW) <sup>*1</sup>	Reference	Current value (A)	Inductance (mH)
0.55 to 0.75	AX-RAO07600042-DE	4.2	7.60	0.55	AX-RAO16300038-DE	3.8	16.3
1.5	AX-RAO04100075-DE	7.5	4.10	0.75	AX-RAO11800053-DE	5.3	11.8
2.2	AX-RAO03000105-DE	10.5	3.00	1.5	AX-RAO07300080-DE	8.0	7.3
3.0	AX-RAO01830160-DE	16.0	1.83	2.2 to 3.0	AX-RAO04600110-DE	11.0	4.6
4.0 to 5.5	AX-RAO01150220-DE	22.0	1.15	3.7	AX-RAO03600160-DE	16.0	3.6
7.5	AX-RAO00950320-DE	32.0	0.95	5.5	AX-RAO02500220-DE	22.0	2.5
11.0	AX-RAO00630430-DE	43.0	0.63	7.5	AX-RAO02000320-DE	32.0	2.0
15.0	AX-RAO00490640-DE	64.0	0.49	11.0	AX-RAO01650400-DE	40.0	1.65
18.5	AX-RAO00390800-DE	80.0	0.39	15.0 to 18.5	AX-RAO01300480-DE	48.0	1.3
22.0	AX-RAO00330950-DE	95.0	0.33	22.0	AX-RAO00800750-DE	75.0	0.8
30.0	AX-RAO00251210-DE	121.0	0.25	30.0	AX-RAO00680900-DE	90.0	0.68
37.0	AX-RAO00191450-DE	145.0	0.19	37.0 to 45.0	AX-RAO00531100-DE	110.0	0.53
45.0	AX-RAO00161820-DE	182.0	0.16	55.0	AX-RAO00401490-DE	149.0	0.4
55.0	AX-RAO00132200-DE	220.0	0.13	75.0	AX-RAO00331760-DE	176.0	0.33
-				90.0	AX-RAO00262170-DE	217.0	0.26
				110.0	AX-RAO00212600-DE	260.0	0.21
				150.0	AX-RAO00173250-DE	325.0	0.17
				185.0 to 220.0	AX-RAO00134440-DE	440.0	0.13
				260.0	AX-RAO00115250-DE	525.0	0.11

\*1. The motor sizes are for heavy duty applications.

## D1000 kit - DC Supply with Regenerative Active Front End system

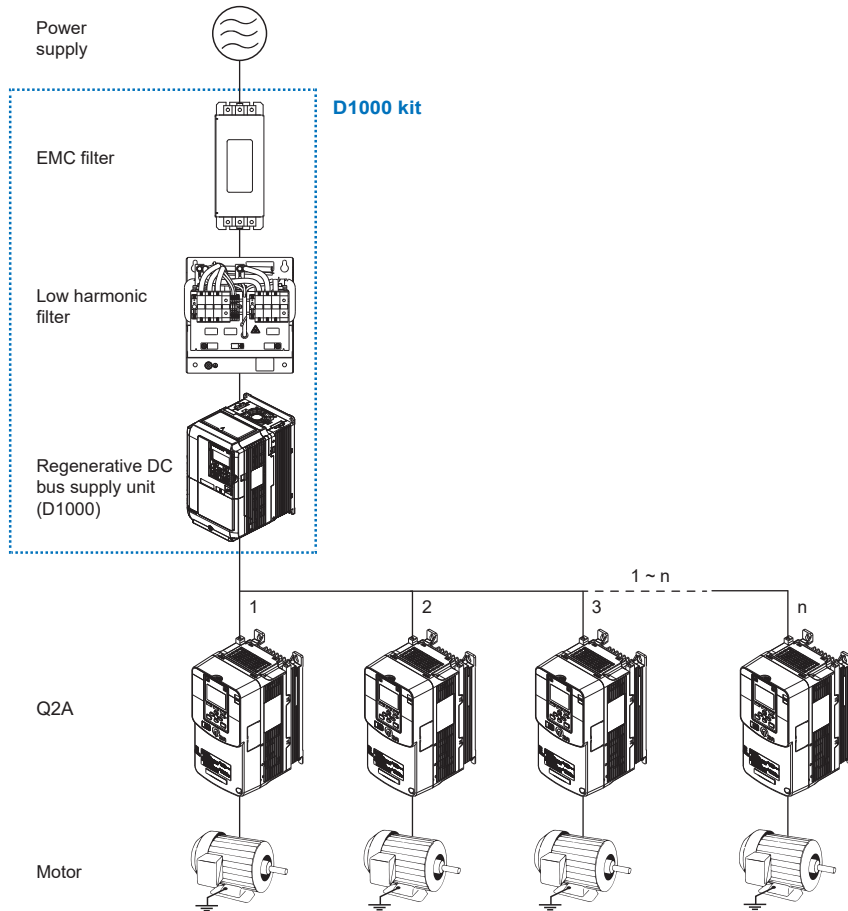

### Regenerative DC bus supply unit (D1000)

Reference: CIMR-DC□	4A0005	4A0010	4A0020	4A0030	4A0040	4A0060	4A0100	4A0130	4A0185	4A0270	4A0370	
Max. applicable motor capacity (kW)	3.7	7.5	15	22	30	45	75	110	160	220	315	
Rated output capacity (kW) <sup>*1</sup>	5	10	20	30	40	60	100	130	185	270	370	
Rated input current AC (A)	8	16	30	43	58	86	145	210	300	410	560	
Rated output current DC (A)	8	15	30	45	61	91	152	197	280	409	561	
Rated input voltage	3-phase 380 to 480 VAC											
Rated output voltage	660 VDC											
Rated frequency	50/60 Hz											
Input power factor	> 0.99											
Carrier frequency	6								4		2	
Degree of protection	IP20					IP00						
Ambient humidity	95% RH or less (without condensation)											
Storage temperature	-20 to 60°C											
Ambient temperature	-10 to 50°C											

\*1. Rated output capacity is calculated with a rated input voltage of 400 V.

### EMC filter

Reference: B84143□	A0020R106	A0035R106	A0065R106	B0180S080	B0400S080	B1000S080
Rated current (A)	20	35	65	180	400	1000
Leakage current (mA)	3.1	3.4	3.4	< 21	< 21	< 40
Rated voltage	300/520 VAC					
Rated frequency	50/60 Hz					
Rated temperature	50°C					
Degree of protection	IP20					

### Low harmonic filter

Reference: B84143G□	0008R176	0016R176	0030R176	0043R176	0058R176	0086R176	0145R176	0210S176	0300S176	0410S176	0560S176
Rated current (A)	8	16	30	43	58	86	145	210	300	410	560
Heat loss (W) <sup>*1</sup>	75	140	165	240	260	300	515	665	855	1398	1970
Rated voltage	305/530 VAC										
Rated frequency	50/60 Hz										
Rated temperature	50°C										
Degree of protection	IP00										

\*1. Heat loss at nominal current and 20°C winding temperature with harmonics.

R1000 kit - Regenerative Braking unit system

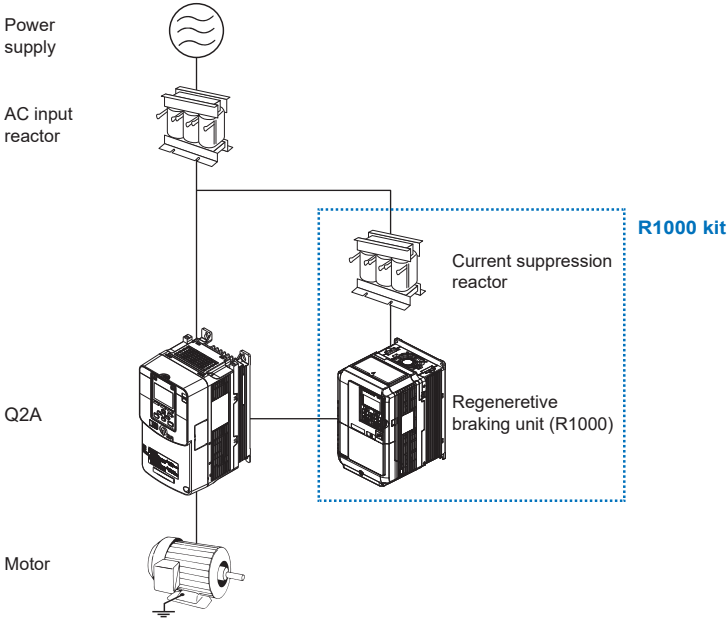

Regenerative Braking unit (R1000)

Reference: CIMR-RC□	4A03P5	4A0005	4A0007	4A0010	4A0014	4A0017	4A0020	4A0028	4A0035	4A0043	4A0053	4A0073	4A0105	4A0150	4A0210	4A0300
Max. applicable motor capacity (kW)	3.7	5.5	7.5	11	15	18.5	22	30	37	45	55	75	110	160	220	315
Rated output capacity (kW)*1	3.5	5	7	10	14	17	20	28	35	43	53	73	105	150	210	300
Rated input current AC (A)	5	8	11	16	22	27	32	43	54	66	81	110	161	237	326	466
Rated output current DC (A)	7	11	15	22	30	36	43	58	73	89	109	149	217	320	440	629
Rated input voltage	3-phase 380 to 480 VAC															
Rated frequency	50/60 Hz															
Power factor	> 0.9 at full load															
Degree of protection	IP20															
Ambient humidity	95% RH or less (without condensation)															
Storage temperature	-20 to 60°C															
Ambient temperature	-10 to 50°C															

\*1. Rated output capacity is calculated with a rated input voltage of 400 V.

Current suppression reactor

Reference: B150□	9105	9106	9107	9108	9109	9110	4118	9111	9112	9113	9114	5002	5008	5011
Rated current (A)	7.5	10	15	25	30	40	50	60	75	100	161	237	326	466
Inductance (mH)	1.2	0.6	0.4	0.3	0.2	0.15	0.12	0.1	0.08	0.06	0.04	0.03	0.02	0.013
Heat loss (W)	21	19	23	36	33	40	46	56	81	72	95	105	120	160

Ordering information

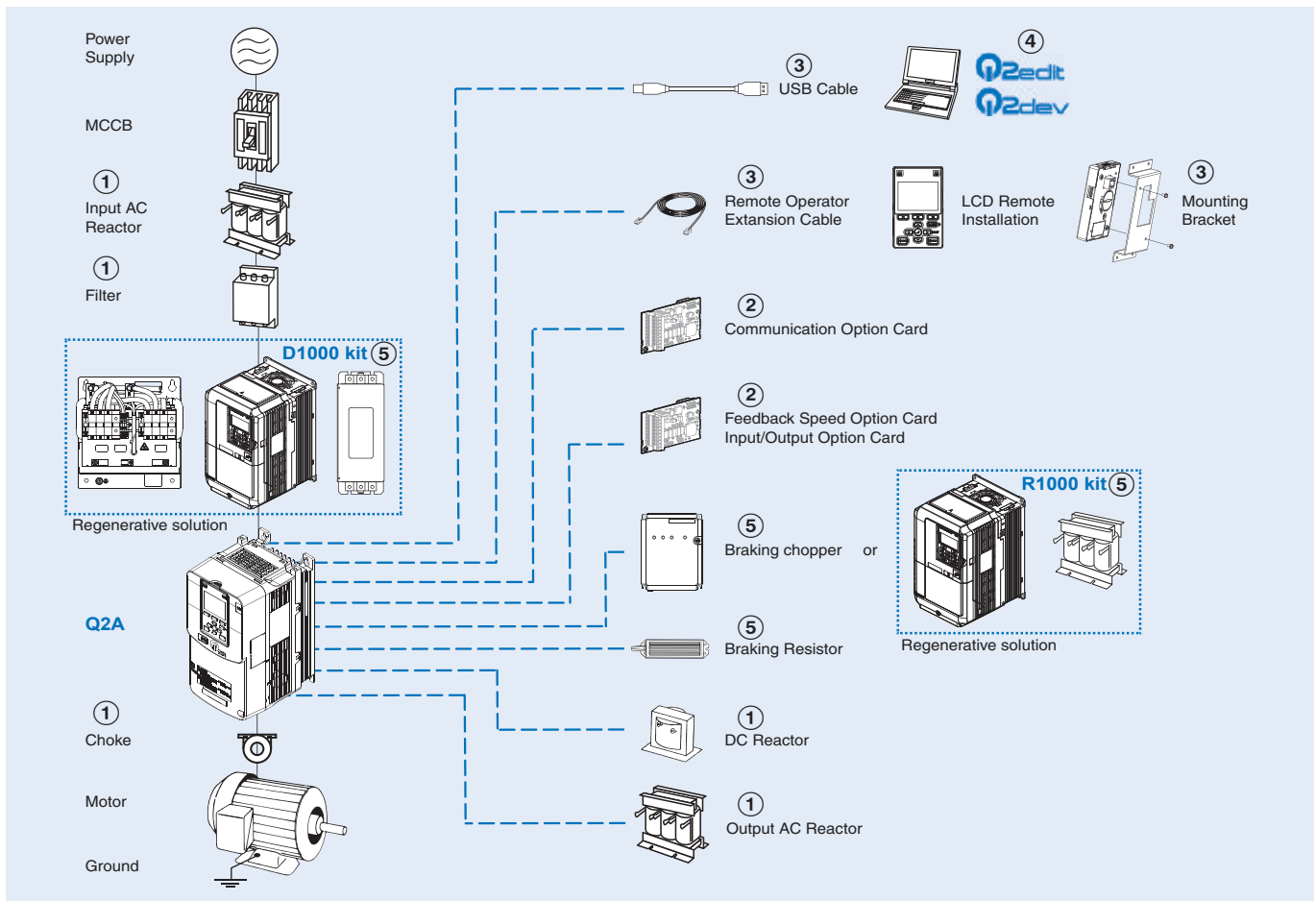

Q2A inverter

Voltage	Specifications				Model
	Heavy Duty (HD)		Normal Duty (HD)		
	Max motor (kW)	Rated current (A)	Max motor (kW)	Rated current (A)	
200 V	0.55	3.2	0.75	3.5	Q2A-A2004-AAA
	0.75	5.0	1.1	6	Q2A-A2006-AAA
	1.5	8.0	2.2	9.6	Q2A-A2010-AAA
	2.2	11	3.0	12.2	Q2A-A2012-AAA
	4.0	17.5	5.5	21	Q2A-A2021-AAA
	5.5	25	7.5	30	Q2A-A2030-AAA
	7.5	33	11	42	Q2A-A2042-AAA
	11	47	15	56	Q2A-A2056-AAA
	15	60	18.5	70	Q2A-A2070-AAA
	18.5	75	22	82	Q2A-A2082-AAA
	22	88	30	110	Q2A-A2110-AAA
	30	115	37	138	Q2A-A2138-AAA
	37	145	45	169	Q2A-A2169-AAA
	45	180	55	211	Q2A-A2211-AAA
	55	215	75	257	Q2A-A2257-AAA
75	283	90	313	Q2A-A2313-AAA	
90	346	110	360	Q2A-A2360-AAA	
110	415	-	-	Q2A-A2415-AAA	

Specifications									Model
Voltage	Heavy Duty (HD) < 460 V		Heavy Duty (HD) ≥ 460 V		Normal Duty (ND) < 460 V		Normal Duty (ND) ≥ 460 V		
	Max motor (kW)	Rated current (A)	Max motor (kW)	Rated current (A)	Max motor (kW)	Rated current (A)	Max motor (kW)	Rated current (A)	
400 V	0.55	1.8	0.55	1.6	0.75	2.1	0.75	2.1	Q2A-A4002-AAA
	0.75	3.4	0.75	2.1	1.5	4.1	1.5	3.4	Q2A-A4004-AAA
	1.5	4.8	1.5	3.4	2.2	5.4	2.2	4.8	Q2A-A4005-AAA
	2.2	5.5	2.2	4.8	3.0	7.1	3.0	6.9	Q2A-A4007-AAA
	3.0	7.2	3.0	6.9	3.7	8.9	3.7	7.6	Q2A-A4009-AAA
	3.7	9.2	3.7	7.6	5.5	11.9	5.5	11	Q2A-A4012-AAA
	5.5	14.8	5.5	11	7.5	17.5	7.5	14	Q2A-A4018-AAA
	7.5	18	7.5	14	11	23.4	11	21	Q2A-A4023-AAA
	11	24	11	21	15	31	15	27	Q2A-A4031-AAA
	15	31	15	27	18.5	38	18.5	34	Q2A-A4038-AAA
	18.5	39	18.5	34	22	44	22	40	Q2A-A4044-AAA
	22	45	22	40	30	59.6	30	52	Q2A-A4060-AAA
	30	60	30	52	37	74.9	37	65	Q2A-A4075-AAA
	37	75	37	65	45	89.2	45	77	Q2A-A4089-AAA
	45	91	45	77	55	103	55	96	Q2A-A4103-AAA
	55	112	55	96	75	140	75	124	Q2A-A4140-AAA
	75	150	75	124	90	168	90	156	Q2A-A4168-AAA
	90	180	90	156	110	208	110	180	Q2A-A4208-AAA
	110	216	110	180	132	250	150	240	Q2A-A4250-AAA
	132	260	150	240	160	296	185	302	Q2A-A4296-AAA
160	304	185	302	200	371	220	361	Q2A-A4371-AAA	
200	371	220	361	220	389	260	414	Q2A-A4389-AAA	
220	414	260	414	250	453	300	477	Q2A-A4453-AAA	
250	453	300	477	315	568	335	515	Q2A-A4568-AAA	
315	605	335	515	355	675	370	605	Q2A-A4675-AAA	

① Line filters

200 V					400 V					
Model Q2A-A□	Line filter (Schaffner)				Model Q2A-A□	Line filter (Schaffner)				
	Filter style	Reference	Current	Quantity		Filter style	Reference	Current	Quantity	
2004, 2006	Footprint type	Q2-FIA4010-SE	10 A	1	4002 / 4004 / 4005 / 4007	Footprint type	Q2-FIA4010-SE	10 A	1	
2010, 2012		Q2-FIA4020-SE	20 A	1			4009 / 4012	Q2-FIA4020-SE	20 A	1
2021, 2030		Q2-FIA4035-SE	35 A	1			4018 / 4023	Q2-FIA4035-SE	35 A	1
2042, 2056, 2070	Book type	Q2-FIA4080-SE	80 A	1	4031 / 4038	Book type	Q2-FIA4050-SE	50 A	1	
2082		Q2-FIA4100-SE	100 A	1			4044 / 4060 / 4075	Q2-FIA4080-SE	80 A	1
2110, 2138, 2169	Busbar termination type	Q2-FIA4170-SE	170 A	1	4089	Busbar termination type	Q2-FIA4100-SE	100 A	1	
2211, 2257, 2313, 2360, 2415		Q2-FIA4410-SE	410 A	1			4103 / 4140 / 4168	Q2-FIA4170-SE	170 A	1
-					4208 / 4250 / 4296 / 4371 / 4389 4453 / 4568 4675	Busbar termination type	Q2-FIA4410-SE	410 A	1	
							Q2-FIA4600-SE	600 A	1	
							Q2-FIA4410-SE	410 A	2	

① Input AC reactors

200 V		400 V	
Model Q2A-A□	Input AC reactor	Model Q2A-A□	Input AC reactor
2004 / 2006 / 2010	AX-RAI02800100-DE	4002	AX-RAI07700042-DE
2012	AX-RAI00880200-DE	4004	AX-RAI07700050-DE
2021 / 2030 / 2042	AX-RAI00350335-DE	4005	AX-RAI03500090-DE
2056 / 2070	AX-RAI00180670-DE	4007	AX-RAI03500100-DE
2082 / 2110	AX-RAI00091000-DE	4009 / 4012	AX-RAI01300170-DE
2138 / 2169	AX-RAI00071550-DE	4018 / 4023 / 4031	AX-RAI00740335-DE
2211 / 2257	AX-RAI00042300-DE	4038 / 4044	AX-RAI00360500-DE
2313 / 2360 / 2415	Please, contact your OMRON representative	4060 / 4075	AX-RAI00290780-DE
		4089 / 4103	AX-RAI00191150-DE
		4140 / 4168	AX-RAI00111850-DE
		4208 / 4250	AX-RAI00072700-DE
		4296	AX-RAI00043350-DE
		4371 / 4389	AX-RAI00034500-DE
		4453	AX-RAI00025350-DE

## ① DC reactors

200 V		400 V	
Model Q2A-A□	DC reactor	Model Q2A-A□	DC reactor
2004 / 2006	AX-RC06750061-DE	4002 / 4004	AX-RC43000020-DE
2010	AX-RC03510093-DE	4005	AX-RC10100069-DE
2012	AX-RC02510138-DE	4007 / 4009	AX-RC06400116-DE
2021 / 2030	AX-RC01110309-DE	4012	AX-RC04410167-DE
2042	AX-RC00840437-DE	4018	AX-RC03350219-DE
2056	AX-RC00590614-DE	4023	AX-RC02330307-DE
2070	AX-RC00440859-DE	4031 / 4038	AX-RC01750430-DE
2082	AX-RC00301275-DE	4044	AX-RC01200644-DE

## ① Output AC reactors

200 V		400 V	
Model Q2A-A□	Output AC reactor	Model Q2A-A□	Output AC reactor
2004 / 2006	AX-RAO07600042-DE	4002	AX-RAO16300038-DE
2010	AX-RAO04100075-DE	4004	AX-RAO11800053-DE
2012	AX-RAO03000105-DE	4005	AX-RAO07300080-DE
2021 / 2030	AX-RAO01150220-DE	4007 / 4009	AX-RAO04600110-DE
2042	AX-RAO00950320-DE	4012	AX-RAO03600160-DE
2056	AX-RAO00630430-DE	4018	AX-RAO02500220-DE
2070	AX-RAO00490640-DE	4023	AX-RAO02000320-DE
2082	AX-RAO00390800-DE	4031	AX-RAO01650400-DE
2110	AX-RAO00330950-DE	4038 / 4044	AX-RAO01300480-DE
2138	AX-RAO00251210-DE	4060	AX-RAO00800750-DE
2169	AX-RAO00191450-DE	4075	AX-RAO00680900-DE
2211	AX-RAO00161820-DE	4089 / 4103	AX-RAO00531100-DE
2257	AX-RAO00132200-DE	4140	AX-RAO00401490-DE
2313 / 2360 / 2415	Please, contact your OMRON representative	4168	AX-RAO00331760-DE
		4208	AX-RAO00262170-DE
		4250	AX-RAO00212600-DE
		4296	AX-RAO00173250-DE
		4371 / 4389	AX-RAO00134440-DE
		4453	AX-RAO00115250-DE

**Note:** This table corresponds with HD rating. When ND is used, please choose the reactor for the next size inverter.

## ① Chokes

Model	Diameter	Description
AX-FER2102-PE	21	For 2.2 KW motors or below
AX-FER2815-PE	28	For 15 KW motors or below
AX-FER5045-PE	50	For 45 KW motors or below
AX-FER5255-PE	52	For 55 KW motors or above

② Option cards

Type	Model	Description	Function
Communication option cards	SI-ES3	EtherCAT	• Used for running or stopping the inverter, setting or referencing parameters, and monitoring output frequency, output current, or similar items through EtherCAT communication with the host controller.
	SI-EM3	Modbus TCP/IP	• Used for running or stopping the inverter, setting or referencing parameters, and monitoring output frequency, output current, or similar items through Modbus TCP/IP communication with the host controller.
	SI-EM3/D	Modbus TCP/IP Dual-Port	
	SI-EP3	PROFINET	• Used for running or stopping the inverter, setting or referencing parameters, and monitoring output frequency, output current, or similar items through PROFINET communication with the host controller.
	SI-EN3	EtherNet/IP	• Used for running or stopping the inverter, setting or referencing parameters, and monitoring output frequency, output current, or similar items through EtherNet/IP communication with the host controller.
	SI-EN3/D	EtherNet/IP Dual-Port	
	SI-EL3	POWERLINK	• Used for running or stopping the inverter, setting or referencing parameters, and monitoring output frequency, output current, or similar items through POWERLINK communication with the host controller.
Input/output option cards	AI-A3	Analog input	• To configure very accurate analog references at high resolution Input signal level: -10 to 10 VDC (20 kΩ) at 4 to 20 mA (250 Ω) Input channel: 3 channels (use a DIP switch to select voltage or current input) Voltage input resolution: 13 bits (1/8192) + encoding Current input resolution: 1/4096
	AO-A3	Analog monitor	• To use analog signals to monitor the drive output frequency and current Output resolution: 11 bits (1/2048) + encoding Output voltage: -10 to 10 VDC (non-insulated) Output channel: 2 channels
	DI-A3	Digital input	• To use digital speed references and MFDI with a maximum 16 bits of resolution Input signals: Binary, 16 bits: BCD4 digits + SIGN signal + SET signal (use parameters to select 6 bits, 8 bits or 12 bits) Input voltage: 24 V (insulated) Input current: 8 mA
	DO-A3	Digital output	• To output insulated digital signals and monitor the operation status of the drive (alarm signals and detecting zero speed) Photocoupler relays: 6 channels (48 V, 50 mA max.) Relay contact: 2 channels (250 VAC at 1 A or less, 30 VDC at 1 A or less)
Feedback speed option cards	PG-B3 <sup>*1</sup>	Motor PG feedback open collector interface	• For speed feedback input by connecting a motor encoder Input: 3 track (one or two tracks), for HTL encoder connection, 50 KHz max Output: 3 track, open collector Encoder power supply: 12 V, 200 mA max
	PG-X3 <sup>*2</sup>	Motor PG feedback line driver interface	• For speed feedback input by connecting a motor encoder Input: 3 track (one or two tracks), line driver, 300 kHz max Output: 3 track, line driver Encoder power supply: 5 V or 12 V, 200 mA max
	PG-F3 <sup>*3</sup>	EnDat encoder	• For speed feedback input by connecting a motor encoder Encoder type: EnDat 2.1/01, EnDat 2.2/01, EnDat 2.2/22 (HEIDENHAIN), HIPERFACE models (SICK STEGMANN) Maximum input frequency: 20 kHz Pulse monitor: Equivalent to RS-422 level Output voltage: 5 V at max. current of 330 mA, 8 V at max. current of 150 mA Wiring length: 20 m max. for the encoder, 30 m max. for the pulse monitor
	PG-RT3 <sup>*4</sup>	Resolver interface	• For motor speed feedback by connecting a resolver (TS2640N321E64 by Tamagawa Seiki Co., LTD) Input voltage: 10 VAC rms 10 kHz Transformation ratio: 0.5±5% Maximum input current: 100 mA rms

\*1. This option card can only be used with CL-V/f and OLV control methods.

\*2. This option card can only be used with CLV, CL-V/f and CLV/PM control methods.

\*3. This option card can only be used with CLV/PM control method.

\*4. This option card can only be used with CLV and CLV/PM control methods.

③ Accessories

Description	Functions	Model	
USB cable	Mini USB to USB cable	AX-CUSBM002-E	
Remote operator cable	3 meters cable to connect the keypad and drive	3G3AX-CAJOP300-EE	
Keypad mounting bracket	This bracket is required to mount the LCD Remote Operator outside an enclosure panel	Screw type	900-192-933-001
		Nut type	900-192-933-002

④ Computer software

Description	Functions	Model
Computer software	Software tool to configure drives and manage parameters	Q2edit
	Software tool to do advanced drive programming	Q2dev

⑤ D1000 kit - DC Supply with Regenerative Active Front End

Rated power (kW)	D1000 kit			
	Regenerative DC bus supply unit (D1000) <sup>*1</sup>	EMC filter <sup>*1</sup>	Low harmonic filter <sup>*1</sup>	Kit code
5	CIMR-DC4A0005BAA	B84143A0020R106	B84143G0008R176	D1KIT40005AAAAAB
10	CIMR-DC4A0010BAA		B84143G0016R176	D1KIT40010AAAAAB
20	CIMR-DC4A0020BAA	B84143A0035R106	B84143G0030R176	D1KIT40020AAAAAB
30	CIMR-DC4A0030AAA	B84143A0065R106	B84143G0043R176	D1KIT40030AAAAAB
40	CIMR-DC4A0040AAA		B84143G0058R176	D1KIT40040AAAAAB
60	CIMR-DC4A0060AAA	B84143B0180S080	B84143G0086R176	D1KIT40060AAAAAB
100	CIMR-DC4A0100AAA		B84143G0145R176	D1KIT40100AAAAAB
130	CIMR-DC4A0130AAA	B84143B0400S080	B84143G0210S176	D1KIT40130AAAAAB
185	CIMR-DC4A0185AAA		B84143G0300S176	D1KIT40185AAAAAB
270	CIMR-DC4A0270AAA	B84143B1000S080	B84143G0410S176	D1KIT40270AAAAAB
370	CIMR-DC4A0370AAA		B84143G0560S176	D1KIT40370AAAAAB

\*1. It is not possible to purchase the Regenerative DC bus supply unit (D1000), EMC filter and low harmonic filter as a separate items.

⑤ R1000 kit - Regenerative Braking unit

Rated power (kW)	R1000 kit		
	Regenerative braking unit (R1000) <sup>*1</sup>	Current suppression reactor (1%) <sup>*1</sup>	Kit code
3.5	CIMR-RC4A03P5FAA	B1509105	R1KIT40003AAAAAA
5	CIMR-RC4A0005FAA		R1KIT40005AAAAAA
7	CIMR-RC4A0007FAA	B1509106	R1KIT40007AAAAAA
10	CIMR-RC4A0010FAA	B1509107	R1KIT40010AAAAAA
14	CIMR-RC4A0014FAA	B1509108	R1KIT40014AAAAAA
17	CIMR-RC4A0017FAA		R1KIT40017AAAAAA
20	CIMR-RC4A0020FAA	B1509109	R1KIT40020AAAAAA
28	CIMR-RC4A0028FAA	B1509110	R1KIT40028AAAAAA
35	CIMR-RC4A0035AAA	B1504118	R1KIT40035AAAAAA
43	CIMR-RC4A0043AAA	B1509111	R1KIT40043AAAAAA
53	CIMR-RC4A0053AAA	B1509112	R1KIT40053AAAAAA
73	CIMR-RC4A0073AAA	B1509113	R1KIT40073AAAAAA
105	CIMR-RC4A0105AAA	B1509114	R1KIT40105AAAAAA
150	CIMR-RC4A0150AAA	B1505002	R1KIT40150AAAAAA
210	CIMR-RC4A0210AAA	B1505008	R1KIT40210AAAAAA
300	CIMR-RC4A0300AAA	B1505011	R1KIT40300AAAAAA

\*1. It is not possible to purchase the Regenerative braking unit (R1000) and current suppression reactor as a separate items.

⑤ Braking unit, braking resistor unit

Inverter		Braking unit		Braking Resistor (10% ED)			Connectable min. resistance Ω												
Max. applicable motor kW	Model Q2A-A□	Model	Qty	Model	Specifications of Resistor	Qty													
200 V class	0.4	2004 HD	Built-in	AX-REM00K1200-IE	100W	200Ω	1	48											
	0.75	2004 ND																	
	1.5	2006 HD			AX-REM00K4075-IE	400W	75Ω	1	16										
		2006 ND																	
	2.2	2010 HD				AX-REM00K4035-IE	400W	35Ω	1	16									
		2010 ND																	
	3.0	2012 HD					AX-REM00K6035-IE	600W	35Ω	1	16								
		2012 ND																	
	3.7	2021 HD						AX-REM00K9020-IE	900W	20Ω	1	9.6							
		2021 ND																	
	5.5	2030 HD							AX-REM02K1017-IE	2000W	17Ω	1	9.6						
		2030 ND																	
	7.5	2042 HD								AX-REM03K5010-IE	3500W	10Ω	1	9.6					
		2042 ND																	
	11	2056 HD									AX-REM19K0008-IE	19000W	8Ω	1	6.4				
		2056 ND																	
	15	2070 HD										AX-REM19K0006-IE	19000W	6Ω	1	5.0			
		2070 ND																	
	18.5	2082 HD											AX-REM19K0008-IE	19000W	8Ω	2	6.4		
		2082 ND																	
	22	2110 HD												AX-REM19K0008-IE	19000W	8Ω	2	6.4	
		2110 ND																	
	30	2138 HD													AX-REM19K0008-IE	19000W	8Ω	2	6.4
		2138 ND																	
37	2169 HD	AX-REM19K0008-IE	19000W	8Ω												2	6.4		
	2169 ND																		
45	2211 HD		AX-REM19K0008-IE	19000W	8Ω											2	6.4		
	2211 ND																		
55	2257 HD			AX-REM19K0008-IE	19000W	8Ω										2	6.4		
	2257 ND																		
75	2313 HD				AX-REM19K0008-IE	19000W	8Ω									2	6.4		
	2313 ND																		
90	2360 HD					AX-REM19K0008-IE	19000W	8Ω								2	6.4		
	2360 ND																		
110	2415 HD						AX-REM19K0008-IE	19000W	8Ω							2	6.4		
	2415 ND																		

Inverter		Braking unit		Braking Resistor (10% ED)			Connectable min. resistance Ω	
Max. applicable motor kW	Model Q2A-A□	Model	Qty	Model	Specifications of Resistor	Qty		
400 V class	0.4	4002 HD	Built-in	AX-REM00K1400-IE	100W	400Ω	1	165
	0.75	4002 ND						
		4004 HD						
	1.5	4004 ND						
		4005 HD						
	2.2	4005 ND						
		4007 HD						
	3.0	4007 ND						
		4009 HD						
	3.7	4009 ND						
		4012 HD						
	5.5	4012 ND						
		4018 HD						
	7.5	4018 ND						
		4023 HD						
	11	4023 ND						
		4031 HD						
	15	4031 ND						
		4038 HD						
	18.5	4038 ND						
		4044 HD						
	22	4044 ND						
		4060 HD						
	30	4060 ND						
		4075 HD						
	37	4075 ND						
		4089 HD						
	45	4089 ND						
		4103 HD						
	55	4103 ND						
		4140 HD						
	75	4140 ND						
4168 HD								
90	4168 ND							
	4208 HD	CDBR-4045D	2					
110	4208 ND	CDBR-4220D	1	AX-REM03K5035-IE	3500W	35Ω	1	19.2
	4250 HD							
132	4250 ND							
	4296 HD							
160	4296 ND							
	4371 HD							
200	4371 ND							
	4389 HD							
220	4389 ND							
	4453 HD							
250	4453 ND							
	4568 HD							
315	4568 ND							
	4675 HD	2						
355	4675 ND			Please, contact your OMRON representative				

ALL DIMENSIONS SHOWN ARE IN MILLIMETERS.  
 To convert millimeters into inches, multiply by 0.03937. To convert grams into ounces, multiply by 0.03527.