

GENERAL CATALOGUE 2004

Automation Systems

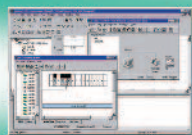

- Programmable Controllers
- Wiring Systems
- Industrial Communication
- Remote I/O
- Industrial Information Technology
- Machine Management Tools
- HMI
- Software

Advanced Industrial Automation

Cat. No. Y201-EN2-02 AS

OMRON

Software

PLC programming	CX-Programmer	673
	CX-Simulator	678
Configuration	CX-Protocol	680
	CX-Motion	682
	CX-Position	683
	CX-Process Tool	684
	CX-Process Monitor	685
	CX-Process Analog I/O Unit Software	686
	Fieldbus	CX-PROFIBUS
Fieldbus	DeviceNet Configurator	688
	DRT2 Series	691
	NX-Server	694
	Visualization	NS Designer
Visualization	Face Plate builder for NS	698
	NT support software	699
	PC based HMI	701
Ordering Information		704

FA Solutions

Personal Computer Software

Classification	Name	Page
PLC programming	CX-Programmer	673
	CX-Simulator	678
Configuration	CX-Protocol	680
	CX-Motion	682
	CX-Position	683
	CX-Process	684
	CX-Process Monitor	685
	CX-Process Analog I/O	686
Fieldbus	DeviceNet Configurator	688
	CX-PROFIBUS	687
	NX-Server	694
Visualization	NS-Designer	696
	NS Face Plate Auto Builder	698
	NT Support Software	699
	CX-Server	701
	CX-Supervisor	702

Ordering Information

Classification
Personal computer software

Copyrights and Trademarks

Microsoft, Windows 95, Windows 98, Windows Me, Windows NT, Windows 2000, and Windows XP are registered trademarks of the Microsoft Corporation.

DeviceNet is a registered trademark of the ODVA (Open DeviceNet Vendors Association).

Other product names and company names that appear in this catalog are the trademarks or registered trademarks of their respective company.

WS02-CXPC1-EV

CX-Programmer

Reduce application development and testing time and increase machine functionality with CX-Programmer.

Programming software for SYSMAC CS, CJ, C, and CVM1/CV series PLC ladder programs

CX-Programmer provides one common PLC software platform for all types of Omron PLC controllers – from micro PLC's up to Duplex processor systems. It allows easy conversion and re-use of PLC code between different PLC types, and the full re-use of control programs created by older generation PLC programming software.

Many powerful documentation features are available to clearly document the intended use and operation of the control code, as this can be stored inside the PLC. An advanced 'project comparison' function is included to allow in-detail comparison between the PLC project and the PC project.

Easy integration with other Omron software products allows sharing of Tag comments to reduce mistakes, reduce development time and increase ease of use.

Maintenance features allow easy searching of contacts and coils with a single click, thereby allowing fast identification of the cause of machine or line stoppages while monitoring, display, and debugging functions reduce engineering time and implementation costs.

Advanced data trace and time chart monitoring reduces maintenance and troubleshooting time. This can then be used to either fine-tune the performance of the machine, or reduce and optimize the cycle time of the machine.

Powerful, Easy-to-use Functions

Powerful, Easy-to-use Ladder Editor

The ladder create, search, and jump operations can be executed with a single keystroke for efficient programming and debugging. Also, the various comment functions make ladder programs much easier to read and search.

- Program with single key inputs. No mouse required.
- Use the cross reference popup function to check a bit or output's ON/OFF status in real time.
- When the program is input, the software automatically performs a circuit check and output-duplication check to prevent input mistakes.
- With one keystroke, jump to a desired location in the program from the search results or program check results displayed in the output window.
- Input various comments (such as rung comments, I/O comments, and circuit comments) to make the program easier to read and search.

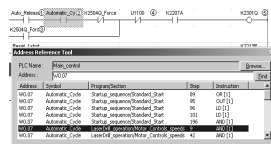

Output duplication check
An output-duplication check is performed automatically when the program is input. Relevant locations are listed and it is possible to jump to those locations.

Cross reference popup
Displays the real-time status of the bit or output at the cursor location. It is also possible to jump to the displayed location.

Rung comment list/jump
Program contents can be checked in a list like a table of contents. It is possible to jump to a listed location.

Rung comment list
The rung comment jump function makes the program easier to search.

Circuit comment, circuit comment list
Circuit comments can be displayed or hidden. Comments attached as notes can be checked when necessary.

I/O comments
It is possible to display/hidden the I/O comments and set attributes such as the number of displayed lines.

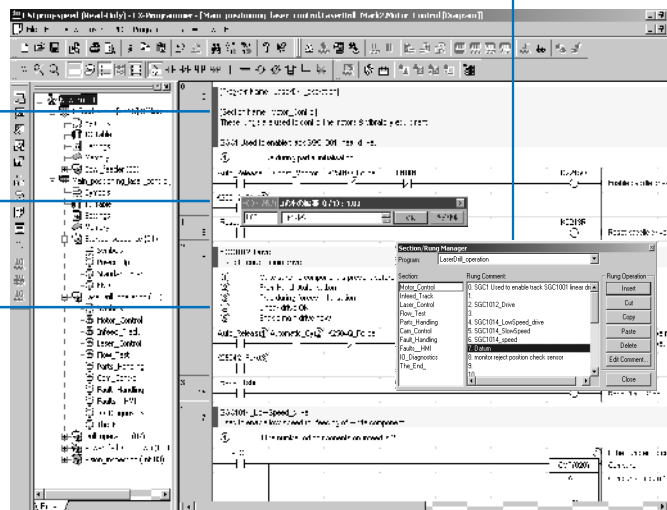

Complete Help and Guidance Functions

The help and guidance function provides helpful support when inputting or creating a program.

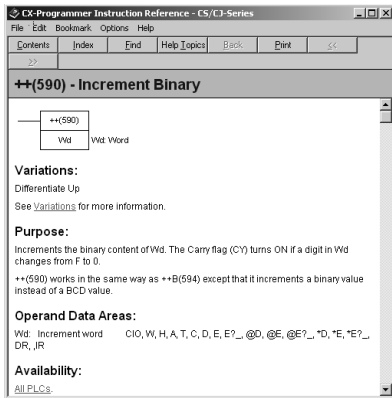

Complete instruction help

The help function can be checked immediately when inputting instructions.

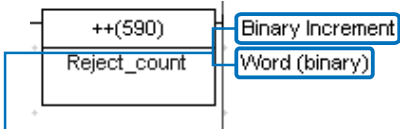

Instruction name and operand description

The instruction name and operand meaning can be displayed in the Ladder Window. (These displays can also be hidden.)

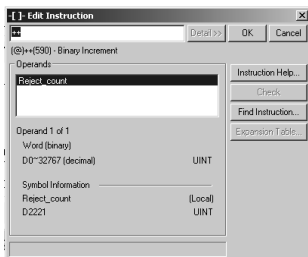

Input help function (Details dialog)

Information on the operand's allowed data areas and setting ranges can be displayed immediately.

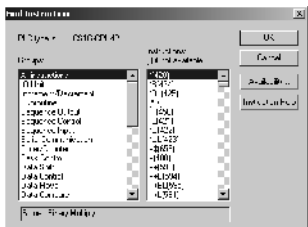

Inputting instructions by instruction group

Instructions can be selected from a list organized by instruction functions.

Program Structure

Detailed Debugging can be performed while displaying the overall program flow.

Program section displays can be further divided when creating or displaying the program. In the following example, the program is created in sections based on processing and it is possible to jump to a specified processing program (section) from the section list.

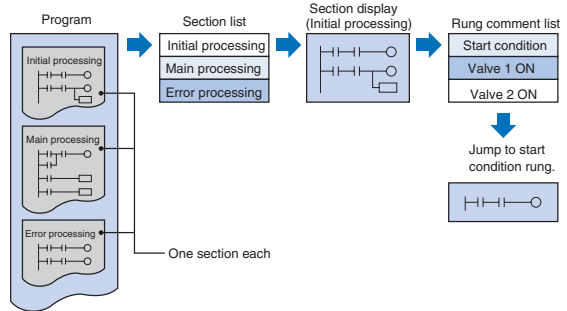

It is possible to jump to a specified section while viewing the overall program in a section list.

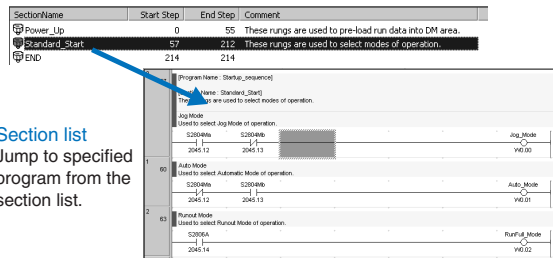

Section list
Jump to specified program from the section list.

Sectioning Program and Reusing Sections

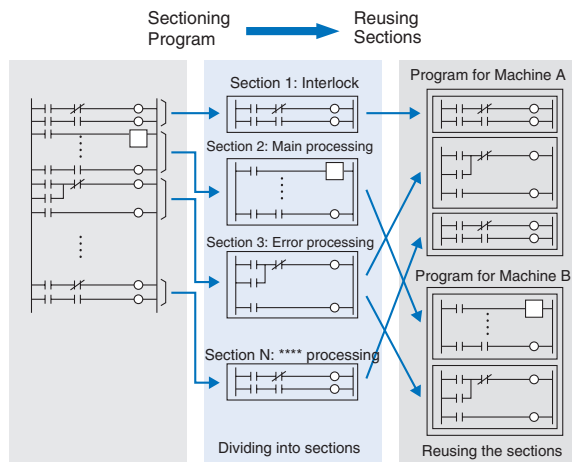

Online Debugging

A Complete Set of Debugging Functions reduces Debugging Time.

- Trace-back searches (searching for bits/outputs with the same address) and consecutive address searches can be performed with a single keystroke.
- Enter the search item by dragging and dropping the item in the ladder window.
- Different parts of the ladder program can be monitored simultaneously with a 2-way or 4-way split screen.
- The I/O monitor function can group locations being monitored, such as steps and processes that are being debugged.

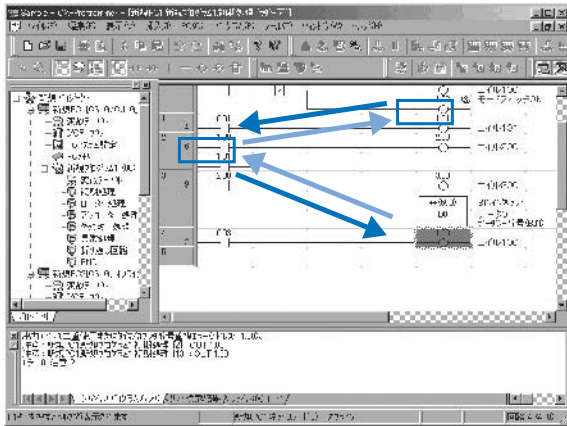

Trace-back Search

Search for the output corresponding to the bit address at the cursor location or search for the bit corresponding to the output at the cursor location.

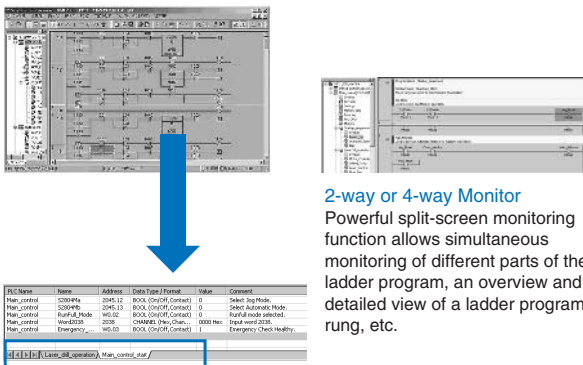

I/O Monitor Function (Watch Window)

- Group different locations that need to be monitored for each process or piece of machinery being debugged.
- Various data displays are available, such as decimal, hexadecimal, signed, and floating-point.
- Registered addresses can be sorted and monitored.
- Registered addresses are automatically saved to a file. It isn't necessary to register the addresses again the next time debugging is performed.

2-way or 4-way Monitor
Powerful split-screen monitoring function allows simultaneous monitoring of different parts of the ladder program, an overview and detailed view of a ladder program rung, etc.

Automatic Online Connections to PLCs make Online Monitoring Easy

The CX-Programmer automatically detects the PLC model, uploads the PLC program and various parameters, and starts the ladder monitor function.

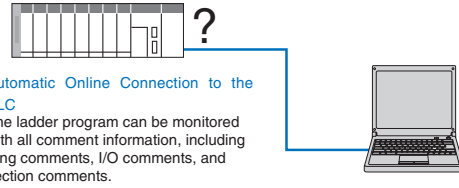

Automatic Online Connection to the PLC

The ladder program can be monitored with all comment information, including rung comments, I/O comments, and section comments.

Online Debugging Functions

- Check continuity efficiently with the ladder wrap-around monitor.
- The online editing function allows several consecutive rungs to be edited at the same time.

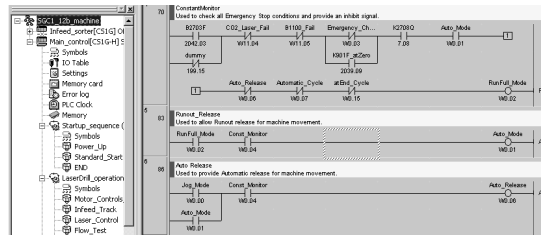

Ladder Wrap-around Monitor

Long ladder rungs are wrapped around to another line before connecting to the right bus bar.

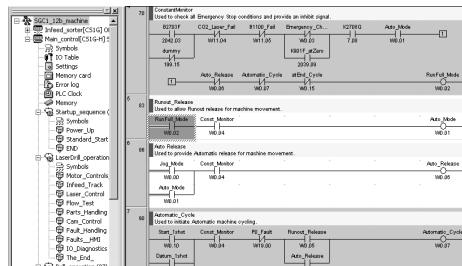

Online Editing

Consecutive ladder rungs can be edited together online. Before edited contents are written to the PLC, a program check is performed automatically and the results are displayed.

Simultaneous Online Debugging by Several People

Program development and online debugging can be performed by two or more people at the same time, so debugging time can be reduced dramatically.

Program Development by Several People

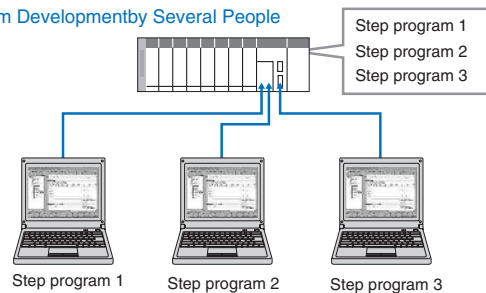

Network Support

Central Management of Information in all PLCs in the Network

Remote maintenance can be performed easily with the CX-Programmer, which supports simultaneous monitoring of the ladder programs and centralized management of data in all of the network's PLCs.

- Data can be collected easily from PLCs in the network just by specifying each PLC's name.
- Various debugging functions, such as I/O monitoring, data traces, and error checks can be performed on a remote PLC just like a directly connected PLC.
- Easily check information such as model numbers and DIP switch settings in other PLCs in the networks.

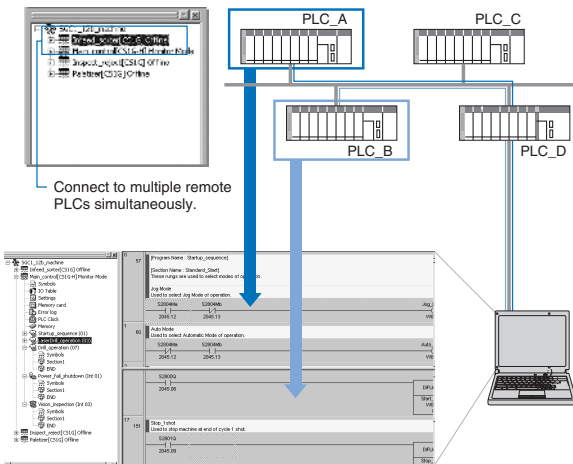

Simultaneous ladder monitoring in more than one PLC

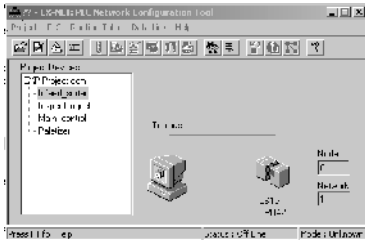

Network configuration

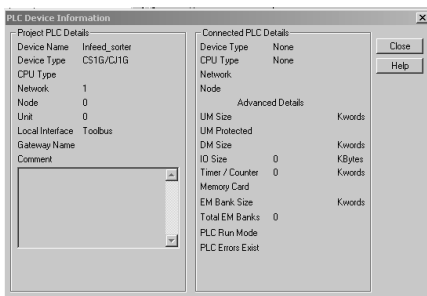

PLC information

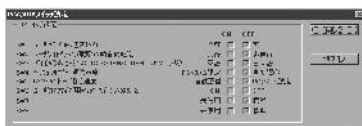

Reading DIP switch settings

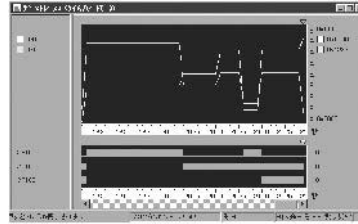

Data Trace

The contents of trace memory (stored in the CPU Unit at high speed) can be displayed graphically.

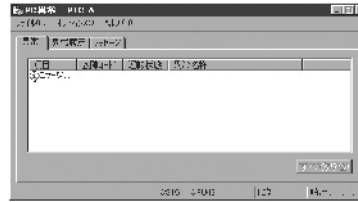

List errors that have occurred and the error log.

Specifications

Basic Functions	Creating, transferring, monitoring, and printing the program Creating and editing the I/O table Creating and transferring the PLC Setup Setting, transferring, and monitoring I/O memory data Online editing Differentiation monitoring Data tracing Time chart monitoring Transferring files to Memory Card
Other Functions (with CX-Net)	Setting, transferring, and starting data links. Setting and transferring routing tables. Communications test Setting and monitoring network communications parameters
Created files	CX-Programmer project files (*.cpx) Contents: Program, I/O memory, PLC Setup, variable tables, rung comments, circuit comments, etc.

Operating Environment

CPU:	Pentium 133 MHz or faster CPU Note: Windows Me requires a 150 MHz or faster CPU. Recommended CPU: Pentium 450 MHz
OS:	Windows 95, 98, Me, 2000, NT 4.0, or XP

Compatible PLCs:

CS Series	CPM2C-S Series
CJ Series	CPM1/CPM1A Series
C1000H Series	CQM1 Series
C2000H Series	CQM1H Series
C200H Series	CV1000 Series
C200HX Series	CV2000 Series
C200HG Series	CV500 Series
C200HE Series	CVM1 Series
C200HX-Z Series	CVM1-V2 Series
C200HG-Z Series	IDSC Series
C200HE-Z Series	SRM1 Series
C200HS Series	SYSMAC Boards
CPM2C Series	
CPM2A Series	

Applicable PLCs

		Name	CX-Programmer
		Model	WS02-CXPC1-EV3
		Communications Mode	Peripheral bus (Tool bus) or Host Link
PLC series		Specifications	Microsoft Windows 95, 98, Me, NT 4.0, 2000, XP
CS1	CS1H-CPU67H/66H/65H/64H/63H		Yes
CJ1	CS1G-CPU45H/44H/43H/42H		(Ver. 2.1 or higher)
	CS1D-CPU67H/65H		
	CS1H-CPU67/66/65/64/63(-V1)		Yes
	CS1G-CPU45/44/43/42(-V1)		
	CJ1H-CPU66H/65H		Yes
	CJ1G-CPU45H/44H/43H/42H		(Ver. 2.1 or higher)
	CJ1G-CPU45/44		Yes
	CJ1M-CPU23/22/13/12		(Ver. 2.04 or higher)
C1000H	C1000H-CPU01		Yes
C2000H	C2000H-CPU01		Yes (Simplex system only)
C200H	C200H-CPU01/02/03/11/21/22/23/31		Yes
C200HX	C200HX-CPU34/44/54/64		Yes
C200HG	C200HG-CPU33/43/53/63		
C200HE	C200HE-CPU11/32/42		
C200HX-Z	C200HX-CPU34-Z/CPU44-Z/CPU54-Z/CPU64-Z/		Yes
C200HG-Z	CPU65-Z/CPU85-Z		
C200HE-Z	C200HG-CPU33-Z/CPU43-Z/CPU53-Z/CPU63-Z		
	C200HE-CPU11-Z/CPU32-Z/CPU42-Z		
C200HS	C200HS-CPU01/03/21/23/31/33		Yes
CPM2A	CPM2A-20CD/30CD/40CD/60CD		Yes
CPM2C (See note 1.)	CPM2C-10CD/10C1D/20CD/20C1D		
CPM2□-S□	CPM2C-S100C/110C		Yes
	CPM2C-S110C-DRT		(Ver. 2.1 or higher)
CPM1	CPM1(A)-10CDR/20CDR/30CDR/40CDR(-V1)		Yes
CPM1A (See note 1.)			
CQM1H	CQM1H-CPU11/21/51/61		Yes
CQM1	CQM1-CPU11/21/41/42/43/44/45		Yes
CV1000 (See note 2.)	CV1000-CPU01(-V1)		Yes
CV2000 (See note 2.)	CV2000-CPU01(-V1)		Yes
CV500 (See note 2.)	C500-CPU01(-V1)		Yes
CVM1	CVM1-CPU01/11(-V1)		Yes
CVM1-V2	CVM1-CPU01-V2/CPU11-V2/CPU21-V2		Yes
IDSC	IDSC-C1DR-A/C1DT-A		Yes
SRM1 (See note 1.)	SRM1-C01/C02(-V2)		Yes

Note: 1. When the WS02-CXPC1-E-V3□ is purchased with only one license and a micro PLC restriction, it can be used only for these PLCs. The Version restricted for only micro PLCs does not support all standard functions.

2. The CX-Programmer does not support SFC.

WS02-SIMC1-E

CX-Simulator

Online debugging of virtual PLCs in the computer

Simulated ladder program execution in a virtual CS/CJ series PLC

WS02-SIMC1-E

Allows program debugging in a single PLC before the actual system has been assembled.
Reduces the total lead time required for machine/equipment development and startup.

Key Features

A debugging environment equivalent to the actual PLC system environment can be achieved by simulating the operation of a CS/CJ Series PLC with a virtual PLC in the computer. CX-Simulator makes it possible to evaluate program operation, check the cycle time and reduce debugging time before the actual equipment is assembled.

Ladder program debugging in a computer

Monitor and debug program execution without the actual PLC.

The developed program can be executed in a virtual PLC within the computer and debugged with the CX-Programmer, just like the actual PLC.

- All of the debugging functions can be used, including the ladder monitor, I/O monitor, online editing, force setting/resetting bits, differential monitor, and data tracing.
- The cycle time can be checked without the actual PLC system.
- Interrupt tasks can also be started.

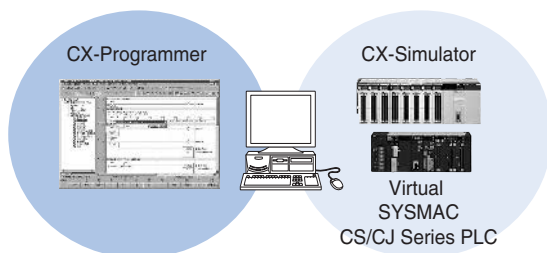

Execute just the required parts of structured/sectional programs and monitor the status of I/O.

Perform efficient debugging operations that cannot be performed in the actual PLC, such as executing single steps, executing single cycles, and inserting break points.

- With the step execution and cycle execution functions, the contents of I/O memory can be monitored in the middle of program execution or after execution of a single cycle.
- Program execution can be stopped when I/O memory data satisfies preset conditions, so that the I/O memory data at that point can be checked.
- A starting point and break point can be specified to execute and debug just that part of the program.



Debug Console

Various execution methods can be selected, such as step execution and cycle execution.

Type	I	Trigger	Time	Status	L	Cycle time
Cycle	1	Cyclic	REACTY	0	0	0.0000 ms
Cycle	1	Cyclic	REACTY	0	0	0.0000 ms
Cycle	2	Cyclic	REACTY	0	0	0.0000 ms
Interrupt	1	Input		0	0	0.0000 ms
Interrupt	3	Interval	0ms	0	0	0.0000 ms

Checking execution times

The virtual cycle time can be checked in advance. Each task can also be started and stopped and each task's cycle time can be checked.



I/O Break Condition Settings

Stop program execution when the specified I/O memory conditions are satisfied, so that the contents of I/O memory at that point can be checked easily.

Virtual External Inputs

Several methods can be used to create and replay virtual external inputs.

The operation of equipment and machinery can be simulated in the PLC as virtual external inputs from several sources.

- Reproducing Virtual External Inputs
When I/O memory data satisfy preset conditions, specified I/O bits and words can be set to desired values after a set time delay (I/O Condition Tool).
- Reproducing External Inputs
Virtual external input data from various sources can be reproduced in the virtual PLC. (Some data sources are operation logs of force-set/force-reset bits and changed I/O memory data, data trace data acquired from an actual PLC, and cyclic data files created in spread sheet software.)

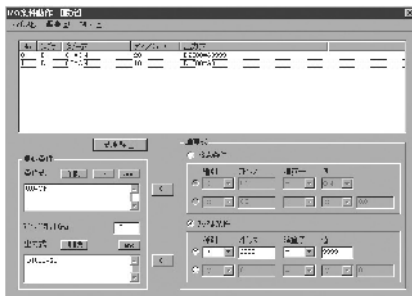
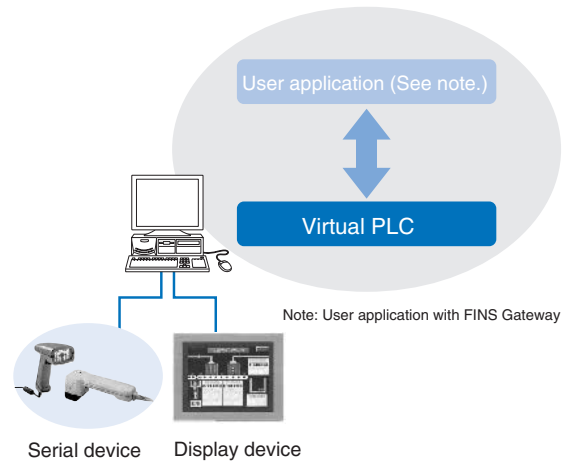

I/O Condition settings



Message communications display function

Complete Debugging with Peripheral Devices

Total system debugging can be carried out by performing communications tests with peripheral devices (serial devices, displays, etc.) and user applications that communicate with the PLC.

- Communications can be debugged with external serial devices connected to the computer's COM port.
- Communications can be tested with Programmable Controllers through NT Link.
- Messages sent by the network communications program can be checked. Messages (frames) sent by the TXD (TRANS-MIT), SEND/RECV (NETWORK SEND/RECEIVE), and CMND (DELIVER COMMAND) instructions can be displayed at the computer.

Specifications	
Basic Functions	Simulates a CS/CJ Series CPU Unit's operation in the computer. ● Virtual external inputs can be input and operation of the virtual CPU Unit can be monitored from the CX-Programmer (continuity monitor, PV monitor, online editing, etc.). ● Check the cycle time.
Other Functions	Execute debugging functions that cannot be performed in the actual PLC (such as single step execution). ● Debug network communications and serial communications.
Created files	PC data directory Contents: Various log files such as Virtual PLC and Debug Settings files
Operating Environment	
CPU:	Pentium 133 MHz or faster CPU Note: Windows Me requires a 150 MHz or faster CPU. Recommended CPU: Pentium 200 MHz or faster
OS:	Windows 95, 98, Me, 2000, NT 4.0, or XP
Compatible PLCs:	
CS Series and CJ Series	

CX-Protocol

Create serial communications protocols to communicate with standard serial devices

Allows program debugging in a single PLC before the actual system has been assembled.
Reduces the total lead time required for machine/equipment development and startup.

Key Features

The CX-Protocol software creates data communications procedures (protocol macros) to exchange data between standard serial devices and the PLC (Serial Communications Unit or Board).

What is a Protocol Macro?

A protocol macro defines the communications protocol for communications between the PLC and any serial device that has an RS-232C port or RS-422A/RS-485 port and uses half-duplex or full-duplex communications with start-stop synchronization. Serial communications can be processed without a ladder program routine once the protocol macro has been written to the Serial Communications Unit or Board (CS/CJ Series Unit/Board, C200HX/C200HG/C200HE Board, or CQM1H Board) and the PMCR instruction has been executed from the CPU Unit's ladder program.

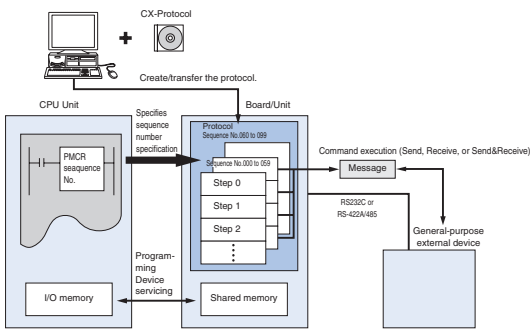

Overview of Protocol Macros

The protocol macro function can be broadly divided into the following two functions.

1. Creation of communications frames (messages)
2. Creation of procedures to send/receive those communications frames (messages)

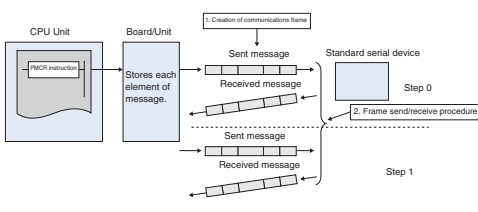

1. Creating communications frames (messages)

1) Communications frames (referred to as "messages" here), which can be understood by general-purpose external devices, can be created according to the communications specifications.



Note: In general, the data area of a send message contains a command code and data. The data area of a receive message contains a response code.

2) Variables for reading data from (or writing data to, if receiving) the I/O memory data area, in the CPU Unit, can be integrated into the messages.

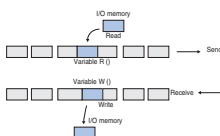

This function has the following advantages:

- Ladder program processing will not be necessary at the CPU Unit when, for example, sending messages after arranging them all in data memory.
- The components of the previously created messages are stored in memory at the Unit or Board, not the CPU Unit. When sending or receiving data, the CPU Unit only has to execute the PMCR instruction.
- When handling one part of the I/O memory data, if the variable required for reading that data has been integrated into a send message, the Unit or Board will automatically read the required data from the I/O memory of the CPU Unit when the PMSU sends the message. Similarly, when writing data from one part of a received message into I/O memory, if the variable required to read the data has been integrated into the reception settings message, the Unit or Board will automatically write the data at the designated position in the message into I/O memory when the Unit or Board receives the message.

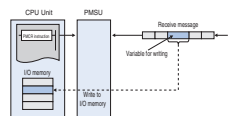
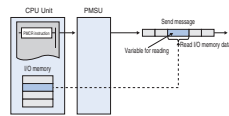
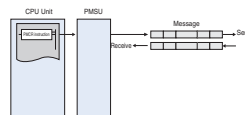
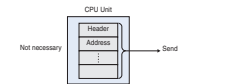

2. Creating procedures to send/receive the communications frames (messages)

1) This function enables all the processing needed to send or receive a message to be handled as one step, and possesses all the commands (step commands), such as Send, Receive, Send&Receive and Wait, that are needed for each step.

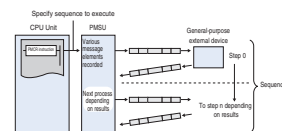
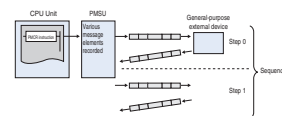

2) This step can be set so that the next process (step/end) depends on the processing result of the previous step. In particular, it is possible to set the sequence so that the next process depends on the contents of one or several set receive messages.

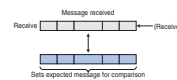

Note 1: A send message created with protocol macro will perform settings for messages that are actually sent.

Note 2: A receive message created with protocol macro will set an expected message for

Developing Communication Protocols

Supports a Wide Range of Communication Protocols

- Send frames and receive frames can be created according to the communications frame (message) specifications of external devices. In addition, variables for exchanging data with the PLC can be incorporated in send and receive frames.
- Supports error check code calculation, frame length calculation during transmission processes, and numeric data conversion between ASCII and hexadecimal.
- Repeat variables can be used, 1:N communications are supported, and write destinations can be switched.
- Supports send and receive time monitoring functions as well as retry processing, so the required communications error processing can be specified easily.
- The interrupt function can send an interrupt to the CPU Unit when receiving data, so high-speed data processing can be performed.
- Expected reception data can be registered and processing can be switched based on the received data.

Complete Set of Debugging Functions

Sequences can be evaluated, saved, and printed with send/receive message tracing.

- Trace function
With a CS/CJ Series PLC, up to 1,700 characters of time-sequential transmission or reception data, which the Board or Unit exchanges with external devices, can be traced. Tracing allows the user to determine which messages were transmitted or received in each step number. The results of tracing can be saved as data in project files or printed.

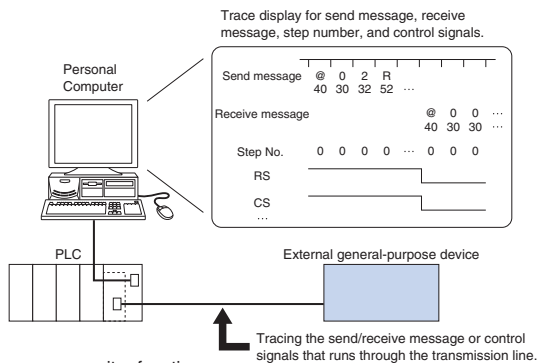

- I/O memory monitor function
Send/receive data stored in the PLC's data areas can be monitored.

Standard System Protocols

Protocols to exchange Data with OMRON Control Devices area Standard Feature.

Data exchange protocols for 13 kinds of OMRON control devices, such as Temperature Controllers and Bar Code Readers, are provided. The standard system protocols can be copied easily and customized.

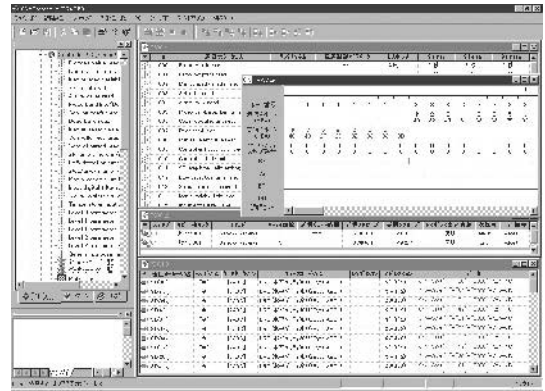

Connected component	Model	Send/receive sequences	
CompoWay/F Master	OMRON components equipped with CompoWay/F Slave	Sending CompoWay/F commands and receiving responses	
Controllers/ Temperature Controllers	Small Digital Controller with Communications Functions (53 x 53 mm)	E5CK	Present value read, set point read, manipulated variable read, etc. Set point write, alarm write, PID parameter write, etc.
	Temperature Controllers with Digital Indications (96 x 96 mm or 48 x 96 mm)	E5CU-A2H0	
	Digital Controllers with Communications Functions (96 x 96 mm)	ES100□	
	High-density Temperature Controller with Communications Functions	E5ZE	
Digital Panel Meters with Communications Output (custom specification)	K3T□	Display value read, comparison value read, write, etc.	
Bar Code Readers	Laser Scanner version	V500	Read start, data read, read stop, etc.
	CCD version	V520	
Laser Micrometer	3Z4L	Measurement condition set, continuous measurement start, etc.	
Machine Vision Systems	High speed, high precision, low cost version	F200	Measurement, continuous measurement, etc.
	High-precision Inspection/Positioning	F300	
	Character Inspection Software/ Positioning Software	F350	
ID Controllers	Electromagnetic coupling	V600	Carrier data read, autoread, write to carrier, etc.
	Microwave	V620	
Hayes modem AT command	MD24FB10V MD144B5V ME1414B2	Initialize modem, dial, transfer data, etc.	

Specifications

Basic Functions	Create protocols, transfer protocols between the CX-Protocol and the Serial Communications Unit/Board, and save files.
Other Functions	Transmission line trace, standard system protocols, PLC I/O memory monitor, PLC error display, protocol print
Created files	CX-Protocol project file (*.psw) Contents: Protocol list, PLC communications settings, trace list

Operating Environment

CPU:	Pentium 90 MHz or faster CPU Note: Windows Me requires a 150 MHz or faster CPU. Recommended CPU: Pentium 166 MHz or faster
OS:	Windows 95, 98, Me, 2000, NT 4.0, or XP

Compatible PLCs:

CS Series, CJ Series, CQM1H Series, and C200HX/HG/HE Series

Compatible Serial Communications Units/Boards:

CS Series	Serial Communications Units/Boards CS1W-SCB21-V1, CS1W-SCB41-V1, CS1W-SCU21-V1
CJ Series	Serial Communications Units CJ1W-SCU21 and CJ1W-SCU41
C200HX/HG/HE	Communications Boards C200HW-COM04, C200HW-COM04-V1, C200HW-COM05, C200HW-COM05-V1, C200HW-COM06, and C200HW-COM06-V1
CQM1H	Serial Communications Board CQM1H-SCB41

WS02-MCTC1-EV

CX-Motion

Creates programs to control the motion controller and monitors controller status

Provides the ideal environment for motion control support, from motion controller program development to full system operation.

Key Features

The CX-Motion software can be used to create, edit, and print the various parameters, position data, and motion control programs (G code) required to operate Motion Controllers, transfer the data to the Motion Control Units, and monitor operation of the Motion Control Units. Increase productivity in every step of the motion control process, from development of the motion control program to system operation.

Motion Control Programs

Easily create motion control G Code programs and parameters.

CX-Motion can create all of the data needed in the Motion Control Unit, such as parameters, position data, and the program. The program can be input in either G code or mnemonics.

- When the Unit is connected online, data can be transferred, verified, and saved.
- Data for different Units can be registered and managed as separate projects.



Operation Monitor

Powerful support during startup and operation

The MC Unit Monitoring function can display vital information at the computer, such as the present position, task being executed, I/O status, error displays, and servo system trace data.

- Up to 20 errors that have occurred in the Motion Control Unit can be stored and displayed (CS1W-MC421/221 and CV500-MC421/221 Motion Control Units only).

Automatic Loading Function

Ideal for flexible, small-lot production lines

Various programs and position data can be stored on disks for the computer running the CX-motion software and the required program/position data can be substituted into the Motion Control Unit when necessary. More than 100 different application programs can be used in this way. A wide variety of programs can be available for execution if the computer is used to store data for the MC Unit.

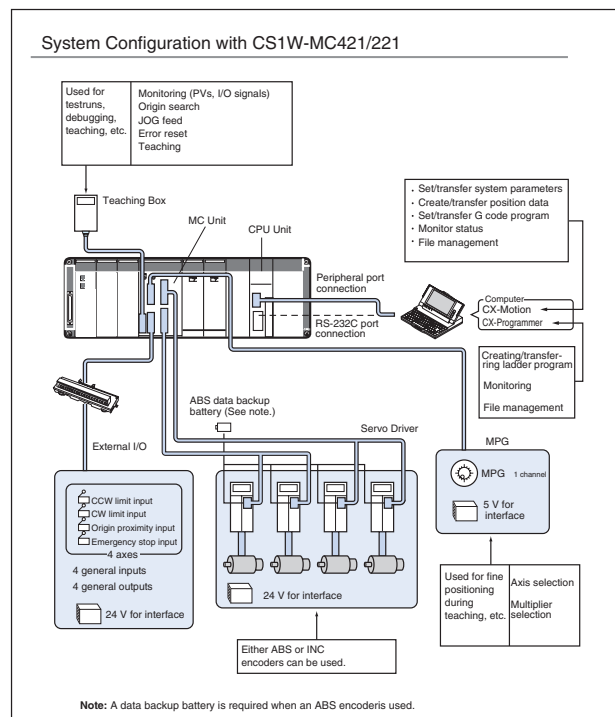
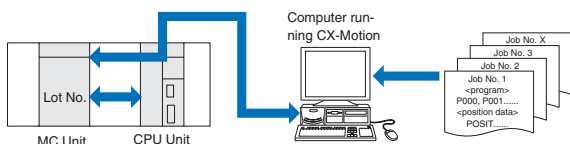

Specifications	
Basic Functions	Create/transfer/print various parameters, position data, and the MC program, transfer data to the MC Unit, and monitor MC Unit's operating status.
Other Functions	Automatic loading, Servo data tracing
Created files	CX-Motion project files (*.mci) Contents: System parameters, position data, program, scripts, etc.
Operating Environment	
CPU:	Pentium 100 MHz or faster CPU
OS:	Windows 95, 98, NT4.0, W2000 or XP.
Compatible PLCs:	
CS Series, C200HX/HG/HE Series, and CVM1/CV Series	

WS02-NCTC1-E

CX-Position

Set, transfer, store, and print position control unit data and monitor operation online

Increase productivity in all position control tasks, from design and startup to system maintenance.

Key Features

The CX-Position software simplifies every aspect of position control, from creating/editing the data used in Position Control Units (NC Units) to communicating online and monitoring operation. The software is equipped with functions that can improve productivity, such as automatically generating project data and reusing existing data.

Creating and managing data

Data can be created for various applications

The CX-Position enables data for multiple NC Units on up to 1,000 PLCs to be handled as 1 project. Data is displayed in tree format and the data for an NC Unit can be moved or copied (overwritten) between PLCs in the project tree. This feature allows data to be edited and re-used in other PLCs or NC Units.

- The CX-Position can read information from NC Units connected online and automatically generate project data.
- Data created for a C200HW-NC□□□ using the SYSMAC-NCT can be imported and used as data for the CS1W-NC□□□ or CJS1W-NC□□□.



NC Monitor

Display the NC units' present positions, error codes, sequence numbers, and I/O status.

The sequence numbers and present positions can be displayed for up to 4 Units. In addition, the contents of the operating memory area and operating data area can be monitored and the error log can be displayed.

Communications

Communicate with NC units through the network.

It is possible to communicate with NC Units through the Fins-Gateway. Depending on the FinsGateway driver version, HostLink or Ethernet. can be used to perform online operations (monitoring operation or transferring/verifying parameters, sequences, etc.) with the NC Unit.

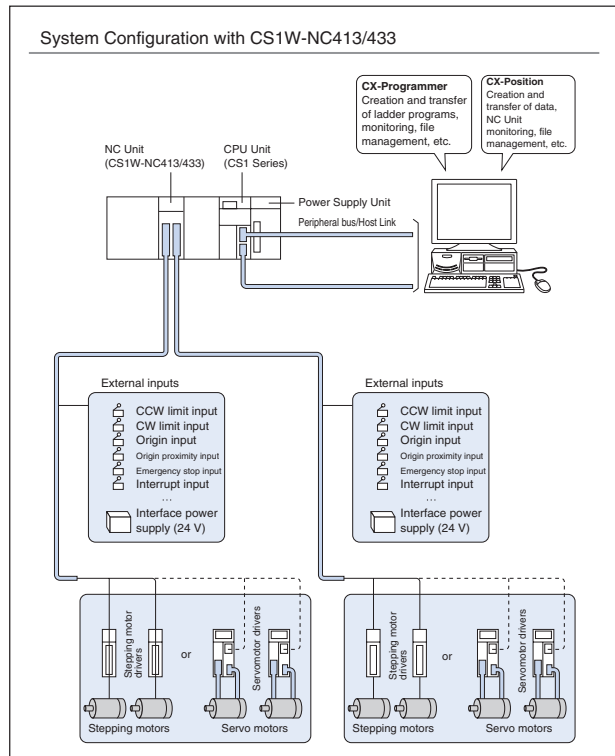
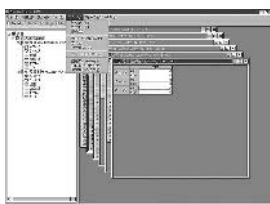

Software

Specifications

Compatible Position Control Units: CS Series: CS1W-NC113/NC133/NC213/NC413/NC433 CJ Series: CJ1W-NC113/NC133/NC213/NC413/NC433

Basic Functions: Create, edit, and print the Position Control Unit's parameter data, sequence data, speed data, acceleration/deceleration data, dwell times, and zone data. Monitor the Position Control Unit's operating status.

Created files: CX-Position project files (*.nci) Contents: Parameter data, sequence data, speed data, acceleration/deceleration data, dwell times, and zone data

Operating Environment

CPU: Pentium 100 MHz or faster CPU

OS: Windows 95, 98, NT4.0, W2000 or XP

Compatible PLCs:

CS Series and CJ Series

WS02-LCTK1-EL01

CX-Process Monitor

Monitors and controls operation of function blocks in loop control units

Monitoring and operation screens can be configured easily with this HMI Software for loop control units,

Key Features

The CX-Process Monitor is HMI (human-machine interface) software that can easily configure standard screens from the tag information created with the CX-Process Tool.

Monitoring the Operating Status

The operating status of function blocks can be monitored.

Bit signals as well as the PV, SP, MV, and other analog signal scan be monitored.

Run and Stop Commands can be sent to the Loop Control Unit.

- Control Screens
- Trend Screens

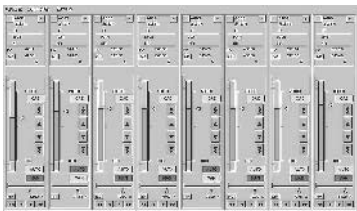

Group Screen

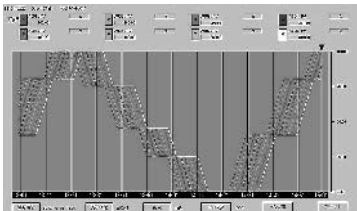

Trend Screen

Monitoring the Alarm Status

Monitoring alarms in function blocks

Alarms that occur in Control Blocks and Alarm Blocks can be displayed and stored in an alarm log.

- Alarm Log Screens
- Annunciator Screens

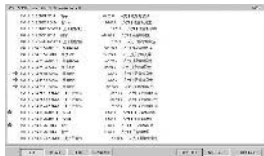

Alarm Log Screens



Annunciator Screens

Controlling Operation

Controlling Operations in Function Blocks

Various adjustments can be made, such as changing a Control Block's settings, switching between Auto and Manual, performing manual operations, and tuning parameters such as PID constants.

- Tuning Screens
- Graphic Screens

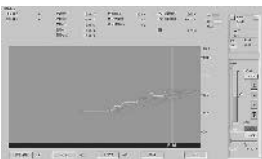

Tuning Screens

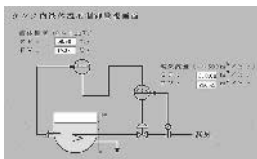

Graphic Screens

Specifications

Compatible Loop Control Unit:	CS Series: CS1W-LC001 Loop Control Unit
Basic Functions:	Monitor the operating status of Loop Control Units. Control basic function block operation.
Created files:	DB folder Contents: Monitor tag settings, screen configuration information, trend data, log data, etc.

Operating Environment

CPU:	Pentium 133 MHz or faster CPU Recommended CPU: Celeron 400 MHz or faster CPU
OS:	Windows 2000, XP, or NT 4.0

Compatible PLCs:
CS Series

Software

WS02-PUTC1-E

CX-Process Analog I/O Unit Software

Sets and monitors operation of process/analog I/O units.

Easily set parameters in 16 models of process I/O units and analog I/O units.

Key Features

Various parameters in process I/O units and analog I/O units can be input easily in a table format or dialog format

Editing and Transferring Set Values

Edit Settings in the DM Area words allocated to Special I/O Units.

Settings can be edited in table format or dialog format.

- The settings can be transferred in one-word units or one-Unit units.
- The settings can be saved as a file.



Simple Monitoring

Operation of the Connected Units can be checked.

An Input Unit's input data can be monitored.
An output value can be output from an Output Unit.

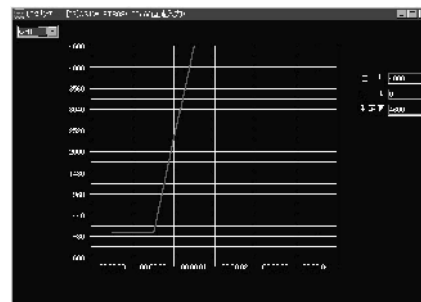

Simulating Operation

Alarm Operation and Other Functions can be checked.

Input values such as voltages can be entered in the Simulation Window with a sliding bar or numeral entry and operation can be checked in the Analog I/O Unit Support Software.

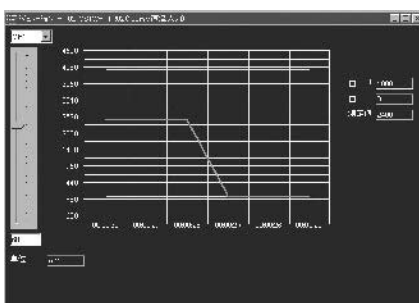

Specifications

Compatible Units: Process I/O Units: CS1W-P□□□□
Analog I/O Units: CS1W-AD□□□, CS1W-DA□□□, and CS1W-MAD□□

Basic Functions: Edit settings in table format. Input settings in dialog format. Transfer settings. Backup settings. Simulate operation of Process I/O Units and Analog I/O Units. Perform simple monitoring. Print settings.

Created files: Process I/O system file (*.ias)
Contents: Settings data, model number information

Operating Environment

CPU: Pentium 133 MHz or faster
OS: Windows 95, 98, 2000, or NT 4.0

Compatible PLCs:

CS Series

PROFIBUS configurator CX-PROFIBUS

Advanced configuration tool that uses FDT/DTM (Field Device Tool and Device Type Manager) Technology

- The PROFIBUS-DP network topology and system characteristics are defined and then downloaded in the OMRON PROFIBUS Master Unit
- Configuration can be done remotely, via other networks as Ethernet or ControllerLink
- Can be used with all OMRON masters

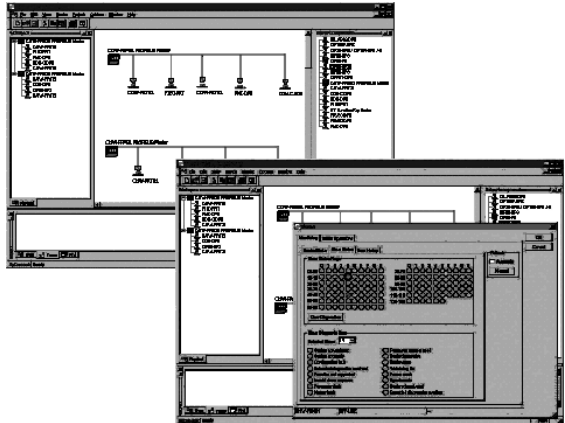

Function

The configuration software package for the OMRON PROFIBUS-DP master is used to define:

- The configuration of the bus system connected.
- Configuration- and parameter data of all connected slave stations.
- Overall bus communication settings.

All configuration data can be prepared off-line and downloaded remotely.

After the initial configuration has been downloaded, the software package can be used for:

- Addition / deletion of slave units or -modules.
- Monitoring the PROFIBUS system status.
- Troubleshooting communication problems.

It is not possible to use other (general-purpose) PROFIBUS-DP Configurator software packages for this purpose

More about FDT/DTM and OMRON CX-PROFIBUS

FDT is a frame application that provides a standard communication interface between software components that support the field devices and systems. These so-called DTMs, can be used in all configuration tools who follow the FDT specification.

The DTM is the management component for a field device or system. It provides all configuration, diagnostics and maintenance information and even graphical user dialogs of the specific device. OMRON's CX-PROFIBUS configuration package is a FDT frame application that includes all DTM's for OMRON PROFIBUS masters and slaves. DTM's of other vendors devices can be added. Also a Generic slave DTM for field devices that only provide a GSD-file for configuration is available.

Software

Ordering Information

Name	Model
CX-PROFIBUS	CX-Profi

Note: C200HW-PRM21 will be supported early 2004.
Remote configuration is not possible for the C200H.

System Configuration

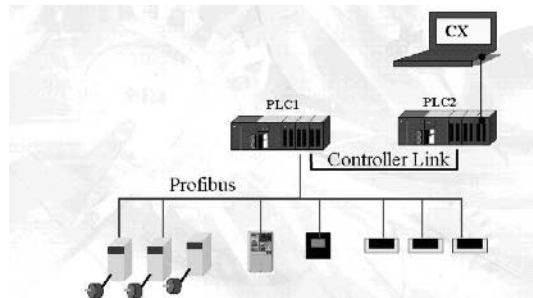

WS02-CFDC1-E/3G8E2-DRM21-EV1

DeviceNet Configurator

Simplifies system construction and maintenance for DeviceNet multivendor networks.

- Graphical interface to simplify network construction.
- DeviceNet Board for personal computers to enable connection from a serial port.
- Monitor devices through an online connection.
- Use Smart Slaves to build an advanced maintenance system.

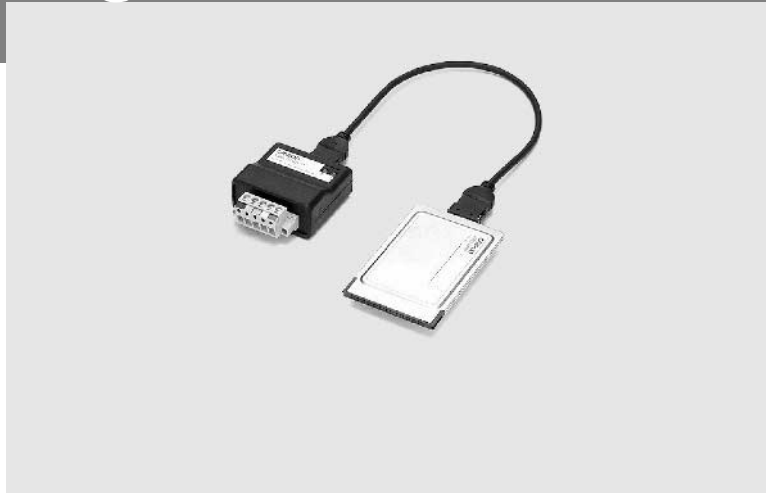

Ordering Information

Name	Operating system	Model
DeviceNet Configurator Software	Windows 95, 98, Me, NT4.0, 2000, or XP	WS02-CFDC1-E
DeviceNet Configurator PC Card	Windows 95, 98, Me, 2000, or XP	3G8E2-DRM21-EV1

System Configuration

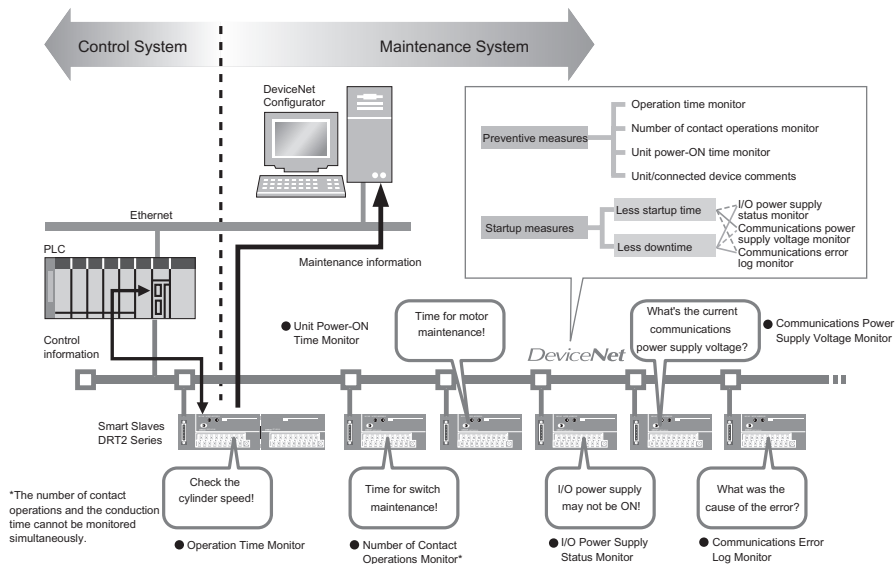

Operating Environment

Operating environment	Hardware	Computer: IBM PC/AT or compatible CPU: Pentium 166 MHz or better (Pentium 150 MHz or better for Windows Me) (Recommended: 200 MHz or better) Recommended memory: 32 MB or more Available hardware disk space: 15 MB or more
Network connection method	Board/Card	3G8E2-DRM21-EV1 DeviceNet Configurator PC Card (PCMCIA) (DeviceNet Configurator Software included)
	Serial	Peripheral port or RS-232C port on CPU Unit or RS-232C port on Serial Communications Unit/Board mounted to CS/CJ-series PLC.

- Note:** 1. Windows is a registered trademark of the Microsoft Corporation.
2. Use version 2.1 or later for the CJ1W-DRM21.

Outline

The DeviceNet Configurator provides function to aid in constructing and operating DeviceNet multivendor networks. These functions are interfaced through graphical windows for easy operation. Offline, virtual networks can be constructed and device settings can be made. If Smart Slaves are used, an advance maintenance system can be constructed by setting and monitoring maintenance information inside the Smart Slaves.

Network Construction and Settings

Easy Network Construction with Graphical Interface

A virtual network construction window provided by the Configurator enables dragging and dropping devices from hardware lists to build a network and make the required settings on the personal computer. The resulting information can be saved in files for downloading to the devices online.

Setting DeviceNet Parameters

Offline, device files can be drug and dropped on a virtual network inside the Configurator to build a network and the parameters for each device can be edited, greatly increasing system design efficiency.

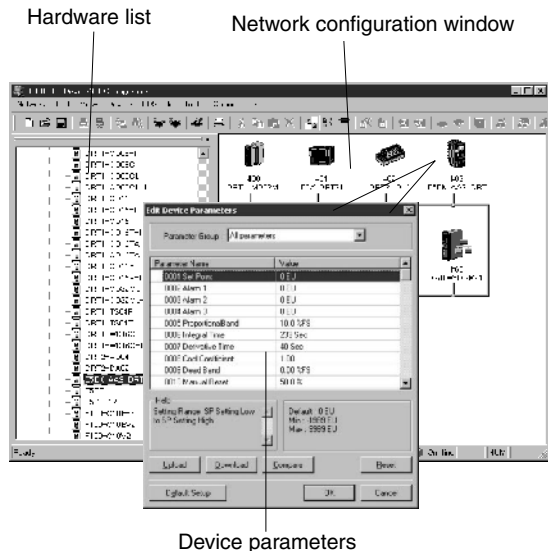

Create Scan Lists Using a Wizard

I/O allocations and slave registrations can be easily performed in the master by using a wizard to create scan lists. The currently registered slaves and allocations can also be easily confirmed.

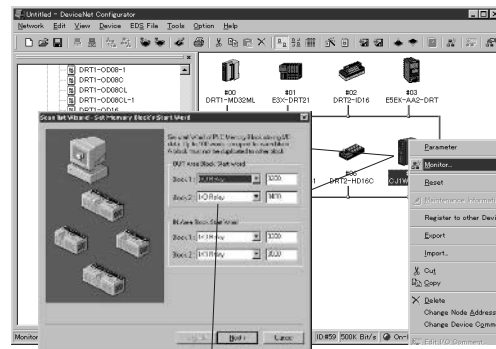

Scan List Wizard

Online Connections

Connect Using a PC Card or Board, or a Serial Port

Software connections from the Configurator are possible using either a DeviceNet Board or Card installed in the personal computer, or through a serial port on an OMRON CS- or CJ-series PLC.

DeviceNet Board or Card

OMRON provides both a PCI Board and a PCMCIA Card to enable direct connection as a node on the DeviceNet network (one node address is allocated).

RS-232C COM Port on Computer

Connection is also possible from the COM port on the computer to the Peripheral port or RS-232C port on CPU Unit or RS-232C port on Serial Communications Unit/Board mounted to a CS/CJ-series PLC that has a DeviceNet Unit mounted to it.

Ethernet Port on Computer

Furthermore, connection is also possible from an Ethernet port on the computer to an Ethernet Unit mounted to a CS/CJ-series PLC that has a DeviceNet Unit mounted to it.

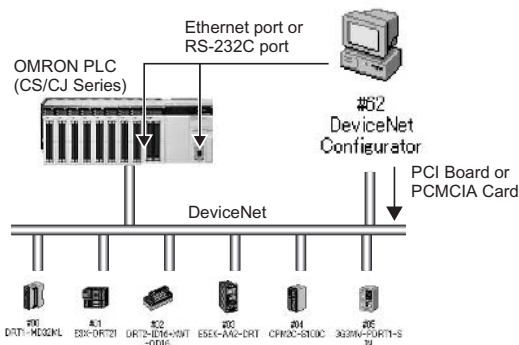

Software

Device Management and Monitoring

Online Device Monitoring

Use Network Uploads to Monitor Devices (See note.)

The following items can be monitored from the CPU Unit of an OMRON CS- or CJ-series PLC.

- Overall network communications status
- Master and slave status
- Unit status
- Communications cycle time
- Error log

Note: Supported only by devices with a monitor function.

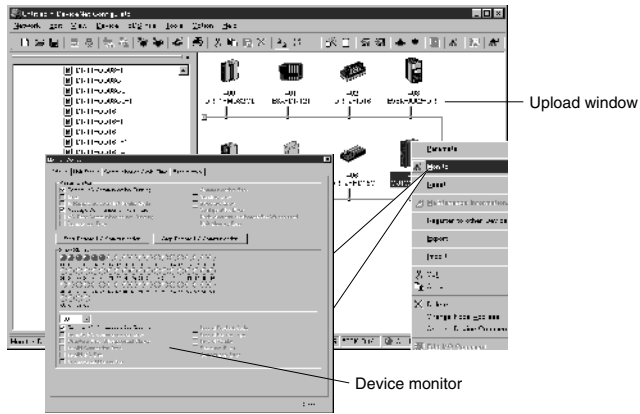

Maintenance System Construction

Use Smart Slaves for an Advance Maintenance System

Smart Slave Maintenance Information

Maintenance information stored in Smart Slaves can be read and used to build a maintenance system that functions separately from the control system.

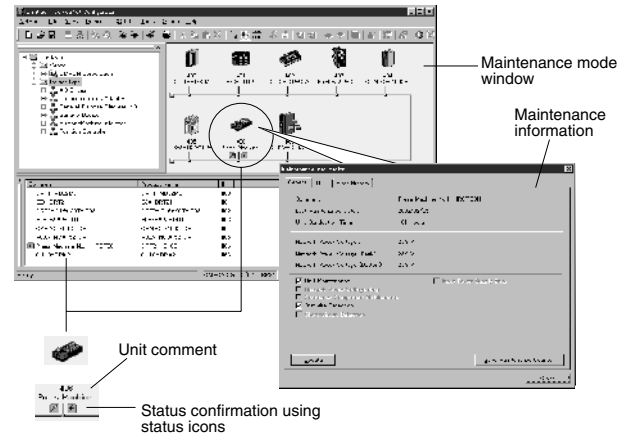

DRT2 Series

DRT2-series Smart Slaves provide you the necessary maintenance and product quality information.

DRT2-series Smart Slave Features

The DRT2-series Smart Slaves do not just handle the I/O information of field devices. They can also deliver a variety of information to improve the operating efficiency of the production equipment. With this information a maintenance system can be fed with information to schedule preventive maintenance actions. This will reduce machine downtime caused by unscheduled repairs during production.

The control system and the maintenance system both use the same DeviceNet wiring. The benefits are: reduced equipment setup time, reduced downtime in the event of a problem, provides preventive maintenance information.

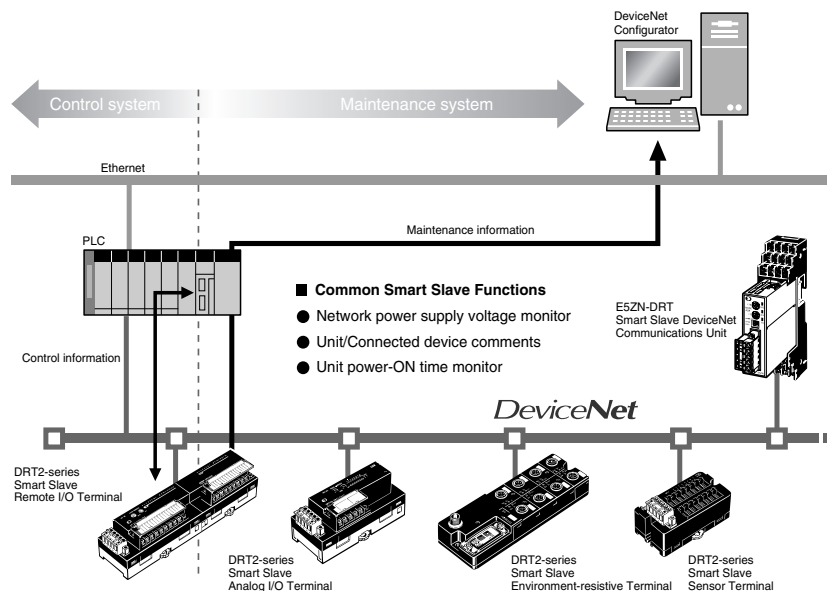
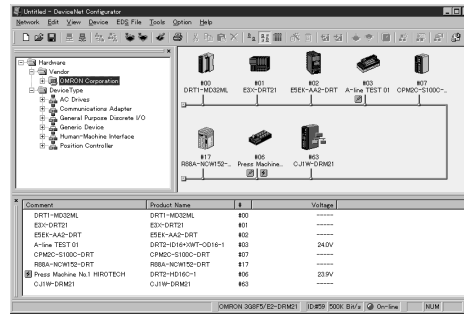

- Reduce Setup Time**
- Network power supply monitor function
 - Input filter function
 - Power-ON inrush current protection function
 - Communications speed auto-detect function
 - Scaling function
 - Analog I/O adjustment function
 - Number of A/D conversion points (conversion cycle) setting

- Reduce Downtime**
- Unit comments function
 - Connected device comments function
 - I/O power supply monitor function
 - Sensor power supply short-circuit detection function
 - External load short-circuit detection function
 - Disconnected sensor detection function

- Improve Maintenance**
- Operation time monitor function
 - Contact operations counter (See note.)
 - Unit ON time monitor function
 - Total ON time monitor function (See note.)
 - Network power supply voltage monitor function
 - Communications error log function
 - Last maintenance date

- Comparator function
- Selectable output value after error
- Cumulative counter
- Moving average processing function
- Peak/bottom hold function

Note: The number of contact operations monitor function and the cumulative ON time monitor function cannot be used simultaneously for the same contact.

Software

Configurator Maintenance Window

Various equipment information can be monitored from the following Configurator window (Ver. 2.20 or later) through DRT2-series Smart Slaves.

Maintenance Mode Window

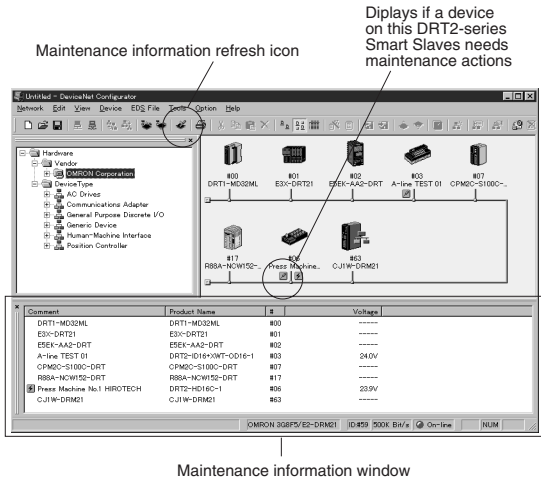

Individual Slave's Maintenance Information Window

A DRT2-series Smart Slave's maintenance information window can be opened by double-clicking the Slave's icon. If an alarm indicator appears next to the Slave's icon then equipment connected to this DRT2-series Smart Slave needs maintenance.

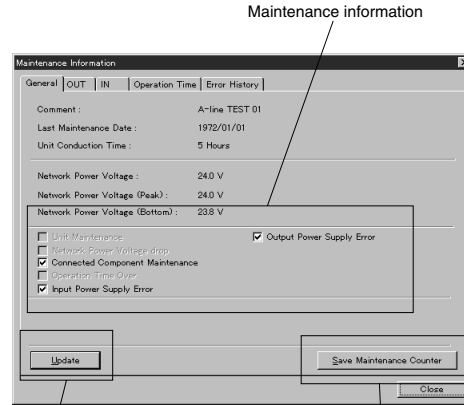

A Smart Slave's maintenance counters are normally stored every 6 minutes. So up to 6 minutes of data may be lost when the power is turned OFF. To prevent loss of Smart Slave's maintenance counters it is possible to store them in flash memory manually.

More details can be viewed by clicking the OUT tab, IN tab, or Operation Time tab.

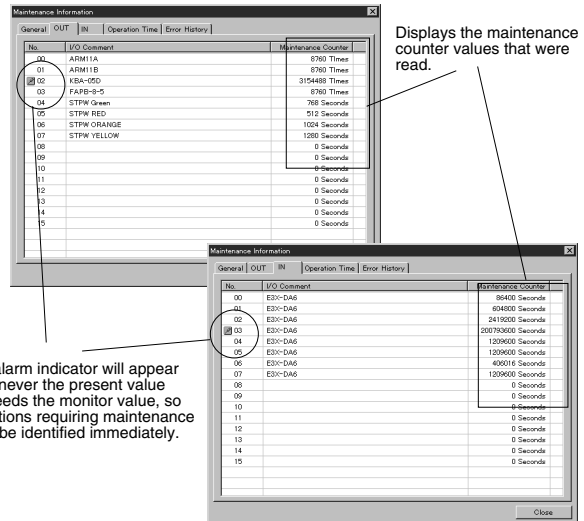

Functions Supported by Smart Slaves

Type of Slave Function	Remote I/O Terminals		Environment-resistive Terminals		Sensor Connector Terminals	Analog Slaves	
	Input	Output	Input	Output	Input	Input	Output
Network power supply voltage monitor function	Supported	Supported	Supported	Supported	Supported	Supported	Supported
Unit comments function	Supported	Supported	Supported	Supported	Supported	Supported	Supported
Connected device comments function	Supported	Supported	Supported	Supported	Supported	Supported	Supported
Unit ON time monitor function	Supported	Supported	Supported	Supported	Supported	Supported	Supported
Operation time monitor function	Supported (Input & Output only)		---	---	---	---	---
Contact operation counter function (See note.)	Supported	Supported	Supported	Supported	Supported	---	---
Total ON time monitor function (See note.)	Supported	Supported	Supported	Supported	Supported	---	---
I/O power supply monitor function	Supported	Supported	---	Supported	---	---	---
Communications error log function	Supported	Supported	Supported	Supported	Supported	Supported	Supported
Input filter function	Supported	---	Supported	---	Supported	---	---
Power-ON inrush current protection function	Supported	---	Supported	---	Supported	---	---
Sensor power supply short-circuit detection function	---	---	Supported	---	Supported	---	---
External load short-circuit detection function	---	---	---	Supported	---	---	---
Disconnected sensor detection function	---	---	Supported	---	---	---	---
Communications speed auto-detect function	Supported	Supported	Supported	Supported	Supported	Supported	Supported
Scaling function	---	---	---	---	---	Supported	Supported
User adjustment	---	---	---	---	---	Supported	Supported
Last maintenance date	Supported	Supported	Supported	Supported	Supported	Supported	Supported
Cumulative counter	---	---	---	---	---	Supported	Supported
Moving average processing function	---	---	---	---	---	Supported	---
Number of A/D conversion points (conversion cycle) setting	---	---	---	---	---	Supported	---
Peak/bottom hold function	---	---	---	---	---	Supported	---
Top/valley hold function	---	---	---	---	---	Supported	---
Percentage change calculation function	---	---	---	---	---	Supported	---
Comparator function	---	---	---	---	---	Supported	---
Selectable output value after error	---	---	---	---	---	---	Supported

* The contact operation counter function and the total ON time monitor function cannot be used simultaneously for the same contact.

WS02-NXD1-E

NX-Server

Easily monitor and record all kinds of I/O data in the DeviceNet Network.

- I/O data being transferred through DeviceNet can be monitored.
- The advanced trigger function allows a specific device's data to be recorded.
- Nodes are not used because the Server is equipped with an original frame analysis engine.
- Data can be accessed without increasing network traffic.
- A development kit for developing applications with the DDE Server and software for operating existing user applications are also available.

NX-Server Functions

- Topic names and data areas can be set freely for each device that you want to monitor or record.
- DDE interface's server name as a public user interface: NETXDNET
- The data size and format (bit, byte, word) can be specified.
- Data logging can be set independently for each device and their trigger conditions can also be set.
- The recorded data can be checked in standard CSV format.
- Nodes are not used because the Server is equipped with an original frame analysis engine.
- Data can be accessed without increasing network traffic.

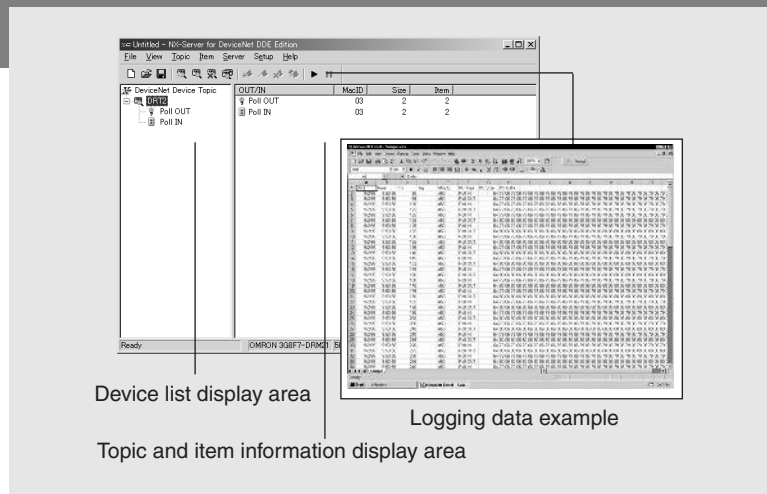

Ordering Information

Name	Model
NX-Server for DeviceNet DDE Edition	WS02-NXD1-E

- Note:**
1. NX-Server is a DDE (Dynamic Data Exchange) Server that collects I/O data and provides that data to higher-level monitoring software.
 2. The 3G8E2-DRM21-EV1 PC Card can be used.

System Configuration

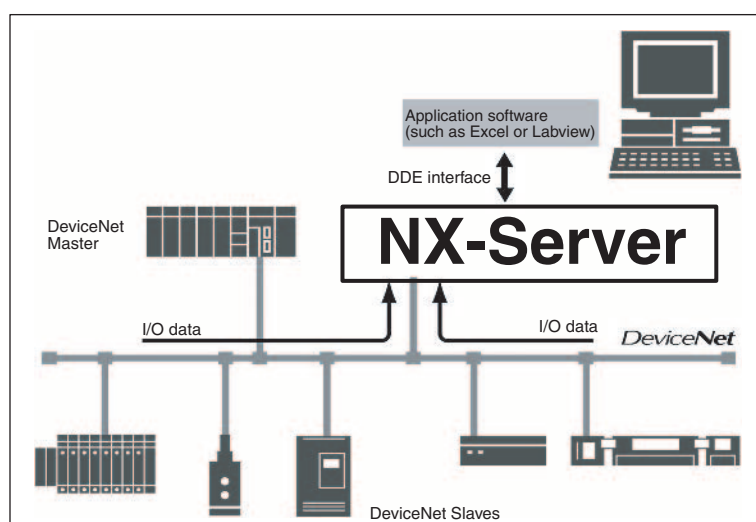

Specifications

Operating Environment

Hardware	OMRON DeviceNet Configurator PC Cards: 3G8E2-DRM21-EV1 PC Card (included with DeviceNet Configurator) National Instruments DeviceNet boards: Any board that supports NI-DNET Software
Computer	IBM PC/AT compatible
OS	When using the 3G8E2-DRM21-EV1: Windows 95, 98
CPU	Pentium 166 MHz or higher
Hard disk space	5 Mbytes min.
Memory	32 Mbytes min.
Floppy disk drive	Drive that can read 1.44-Mbyte, 3.5-inch, 2HD floppy disks
Display	VGA or higher

Note: Windows is a registered trademark of Microsoft Corporation.

NS-NSDC1-EV1

NS Designer

Efficient development process for screen creation, simulation and project deployment.

The NS-Designer is used to create screen data for NS-series Programmable Terminals. The NS-Designer can also check the operation of the created screen data on the computer.

Screen Creation

Develop Screens More Efficiently with Easy-to-use Support Software. The NS-Designer has about 1,000 standard functional objects with associated graphics and advanced functions, so even first-time users can create screens easily just by arranging functional objects in a screen.

The NS-Designer is also equipped with a variety of functions that make it easy to create screens for common applications. Screen development is far more efficient with the NS-Designer.

- Color Change when the Upper or Lower Limit Is Exceeded

The upper limit can be monitored just by checking the box and setting the upper limit value.

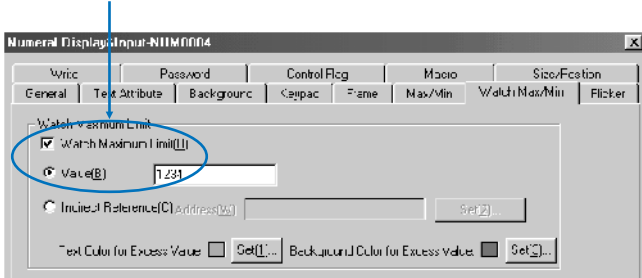

- Indirect Specification of the Display Color (Dynamic Display) with the Color Code (0 to 255)

The color can be specified indirectly by checking the box and setting the address being used for indirect specification.

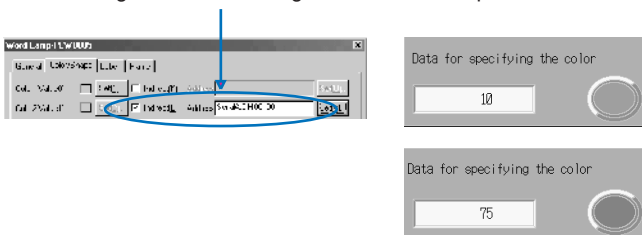

- Flow Text Display for Alarm/Event Messages

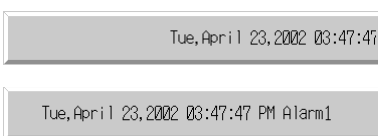

Screen templates

Make one common screen (sheet) that overlaps other screens (to save having to recreate the same part, such as a menu, in every screen).

- Sheets

A feature that is common to several screens can be registered as a sheet. The common feature can be added to any screen just by applying the corresponding sheet to the screen. (Up to 10 sheets can be created for one project.)

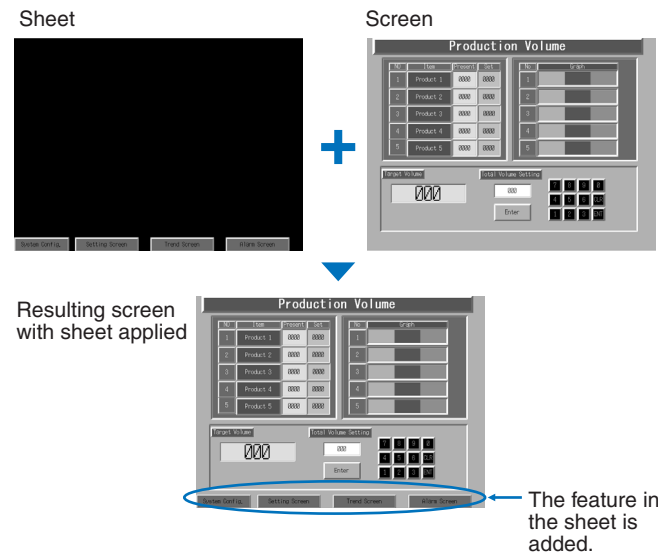

Making Table Form Objects

Speed up creating tables containing similar functional objects.

- Tables

The same kind of functional objects (such as Buttons, Text, or Numerical Display & Input objects) can be created together in a table just by specifying the kind of functional object, number of rows, and number of columns in the table. In addition, the properties for functional objects can all be set together and PLC addresses can be allocated automatically.

It is also possible to add headings for each row and column.

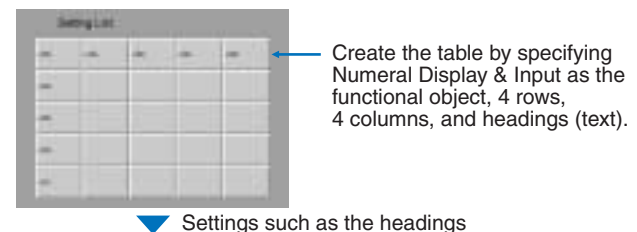

	Temperature Setting	Pressure Setting	Preparation	Process
Product A	000	00Pa	5min	2hr
Product B	000	00Pa	0min	2hr
Product C	1000	10Pa	10min	0hr
Product D	000	00Pa	0min	4hr

The Operation of Screen Data Can Be Confirmed Easily on a Personal Computer

Check the operation of functional objects (buttons, lamps, numeral displays, etc.) on a personal computer.

- Simulation via the "Test Function"

When a test is started, a test screen and virtual PLC will be displayed on the computer.

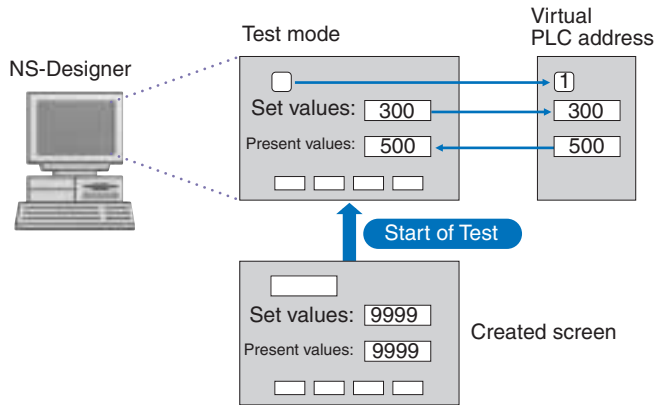

Operating (clicking with the mouse) the functional objects on the test screen will change the corresponding address in the virtual PLC. Conversely, changing the content of a virtual PLC address will change the corresponding functional objects. It is also possible to confirm pop-up screens. This function can be used to confirm the actual operation of a screen during the edition.

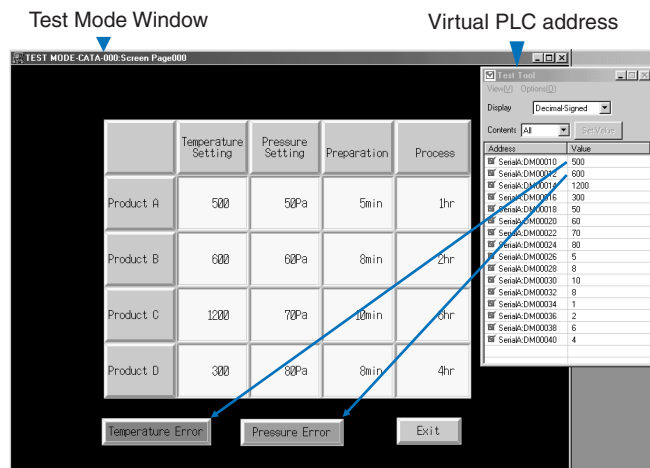

The test function enables debugging screens without NS and PLC Hardware.

- Validation

Validation checks functional objects against checkpoints (such as PLC addresses setting miss), and detected errors are listed. The listed errors can be checked before transferring the screen data to the PT.

Built-in Recipe Function for Fast Production Changeovers

Data blocks (recipe function) allow several numeric values and/or character strings to be transferred to/from memory areas, such as PLC data areas. Data blocks can be used to change the system's production setup even faster.

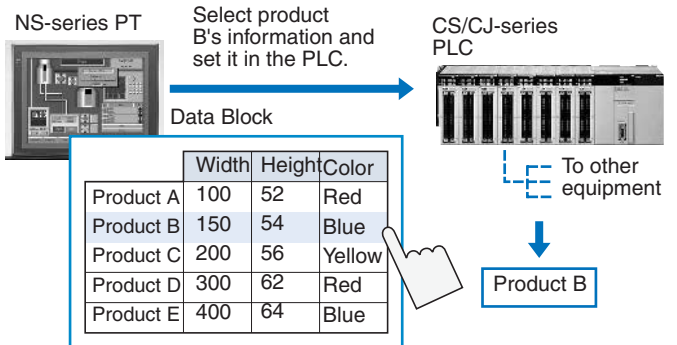

- Register Recipes Easily by Writing Product Information in Data Blocks.

The Data Block (recipe) function consists of records and fields. Set the communications address and data format for each field. The records contain the data for each field.

For example, when production conditions are assigned to the fields, write the values for the product in that record so that the values required for production of the product will be transferred to the PLC.

Using this function can drastically reduce the time required to switch the production arrangement. This function also helps avoid production problems from errors such as recipe transmission mistakes.

	Field A • Address • Data format	Field B • Address • Data format	Field C • Address • Data format
Record 1			
Record 2			
Record 3			
Record 4			

WS02-NSFC1-E

Face Plate builder for NS

Automatically create loop control unit/board control and tuning screens for NS-series PTs

Create touch panel screens with the touch of a button and dramatically reduce development time.

Key Features

The Face Plate Auto-builder automatically creates a NS-series (touch panel) control or tuning screen from the CX-Process Tool's function block information.

Significantly reduces the engineering time required by combining LCB/LCU and the NS Series.

- Automatic generation of control screens and tuning screens. Automatic generation of NS screen data by the software from tag information created with CX-Process Tool.
- NS communications address allocation, ladder programs, etc., are completely unnecessary.
- Data that has been generated can be freely edited and processed by NS-Designer (NS screen creation software).

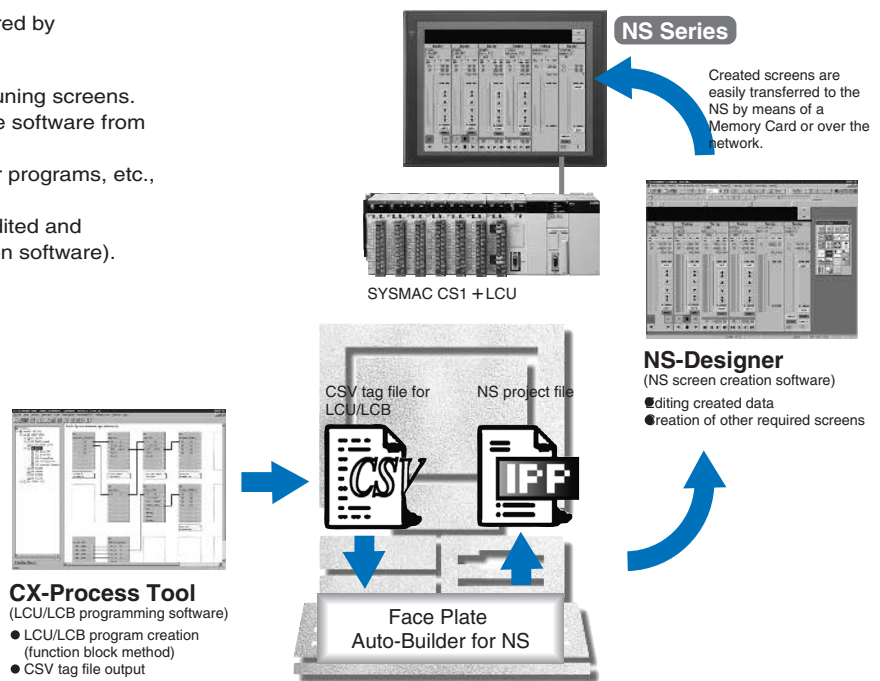

■ Specifications

Product name	Specifications	Model number
Face Plate Auto-Builder for NS	CSV tag files for LCU/LCB used in Face Plate Auto-Builder for NS	WS02-NSFC1-J

NT Shell

NT support software

Easy-to-operate Windows-based Look & Feel Interface with New Functions and More Advanced Visual Expressions

Greatly Improved Support Software

Windows Look and Feel environment ensures easy operation, allowing anyone to create screens quickly and easily. The enhanced ON/OFF simulation function and easy application of existing screen data accelerate product development and designing.

Edit screen

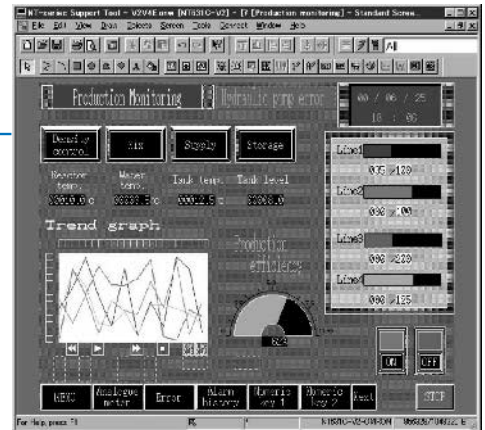

- The arrow keys on the keyboard are used to move elements dot by dot.
- Displays element and cursor coordinates.
- The window being manipulated can be displayed or not displayed.
- Zooms up to 800%.

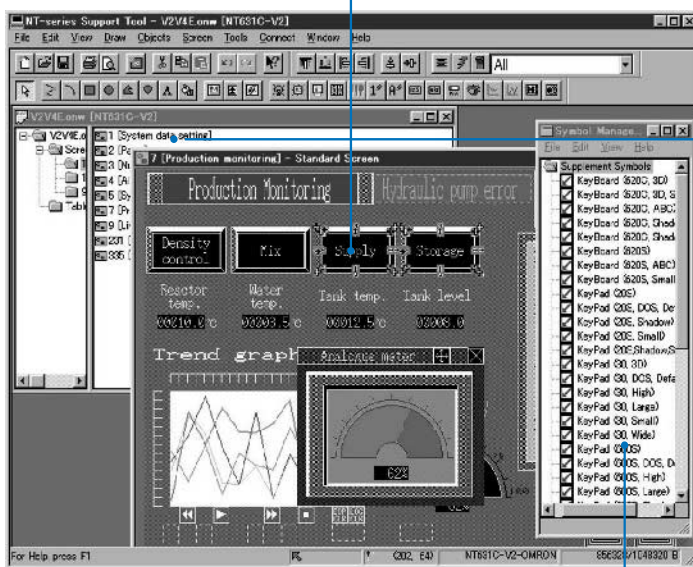

Application Manager

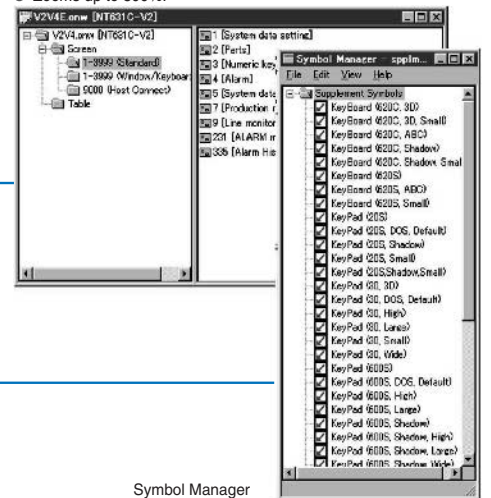

Symbol Manager

Software

Better Data Reusability for Even Greater Design Efficiency

Share I/O Comments

I/O comments can be imported from ladder program and other files created on the CX-Programmer. The imported I/O comments can be used as guide text to reduce the time and trouble required to input comments. Importing comments also helps to eliminate mistakes in PLC I/O allocations, and greatly reducing the time required later for corrections.

Effectively Use Existing Screen Data

It is possible to load screens and tables independently from different screen data files. Existing screen data can now be used efficiently.

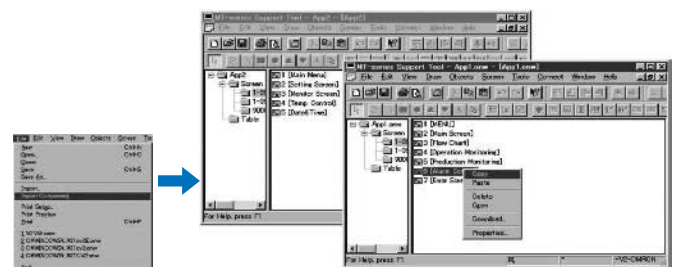

Powerful Editing and Screen-creation Functions for Easier Screen Production

Complete Display Functionality for Guide Characters and Numeric/Character Strings

Guide Characters

Guide characters for touch switches and lamps can be displayed on multiple lines, can be turned ON and OFF, and can be left-, right-, or center-aligned.

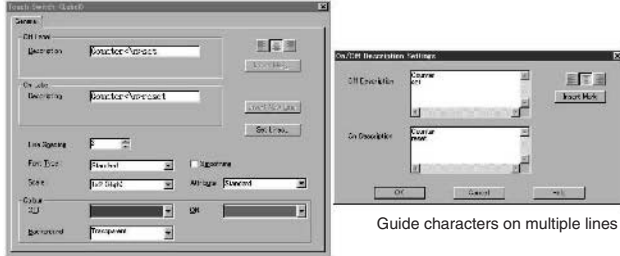

Guide characters on multiple lines

Filter Function

Example to display only the bar graph. The filter function makes editing easier by displaying only the elements you select for modification.

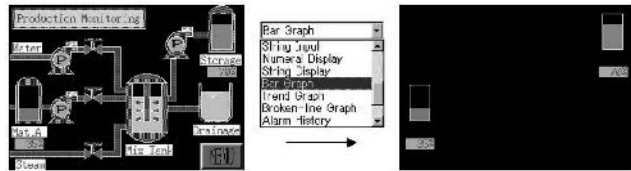

The above example is to display only the bar graph.

And, More Power After Completing Screen Creation

Easy and Flexible Documentation

Screens, memory tables, and other data can be output in RTF format to enable easy creation of specifications and other documents.

Special Utility to Transfer Screen Data

It is possible to transfer screens by using a special software application instead of the NT Support Software. The software application can be set up separately.

ON/OFF Simulation on Edit Screen

Easily confirm the ON/OFF status of lamps and touch switches from a personal computer.

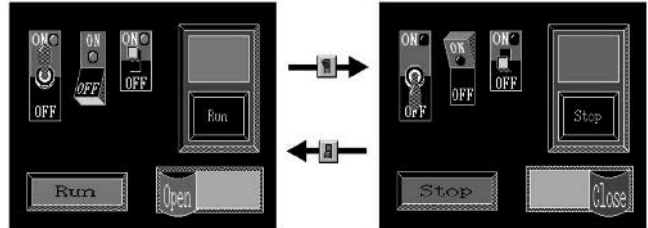

Simulations are performed with screens made from standard elements. The touch switches, lamps, and other elements that have been made can be easily registered with the symbol manager.

Element Alignment

Elements can be top-, bottom-, left-, right-, or center-aligned automatically.

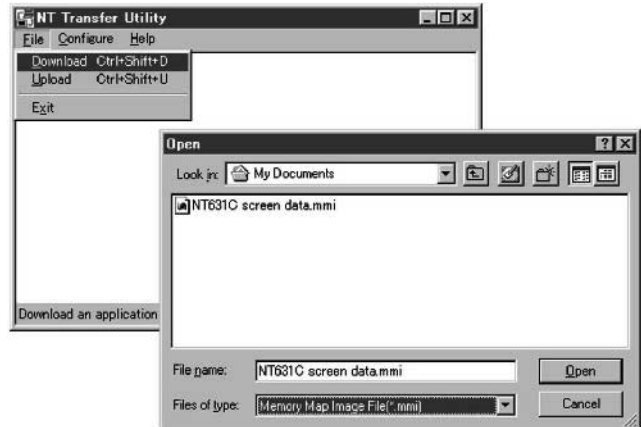
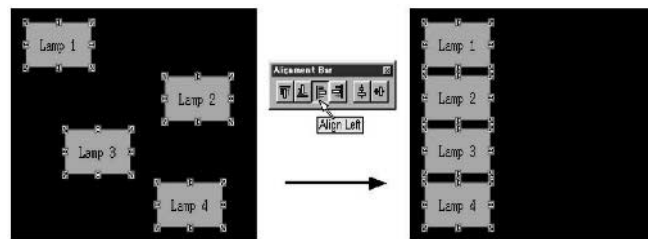

System Requirements

Processor	Pentium 100 MHz min.
Memory	32 MB RAM min.
Available hard disk space	Software: 17 MB, Installer: 3 MB, Sample elements: 32 MB
OS	Windows 95, 98, or NT 4.0 (not Windows 3.1)
Media	CD-ROM

Ordering Information

Name	Specifications	Model
Windows-based Support Software (on CD-ROM)	Windows 95, 98, or NT 4.0	NT Shell
Memory Unit to transfer screens	For NT631/631C and NT31/31C	NT-MF261
Cable to transfer screens	IBM PC/AT or compatible	XW2Z-S002

CX-Server OPC / Lite PC based HMI

CX-Server Lite and OPC connects the OMRON PLC systems to the world of Microsoft Office, Microsoft Programming Languages or any OPC client.

By simply importing the CX-Server ActiveX® components into your application you can create a link to the PLC that lets you write production parameters and read production data, for example.

These products allow easy visualisation of machine information, through standard ready-to-use (graphical) components to create production and machine statistic reports or simple control applications.

No specialised knowledge of PLC systems or networks is needed to use these products. Any VBA or Visual Basic user can use CX-Server Lite and OPC successfully.

The products represent a substantial time saving compared with conventional programming.

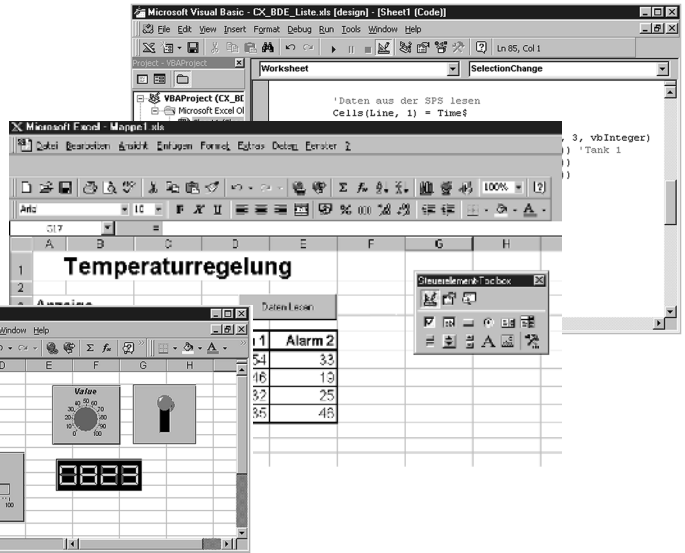

General Data

	Specification
Supported PLC systems	CS1, CJ1, C20, CXxK, CXxH, CXxp, SRM1, CPM, CQM1, CQM1H, C200H/-HS/-HX/-HG/-HE, C1000H, C2000H, CV/CVM1
Communication	<ul style="list-style-type: none"> Peripheral port and Host Link port via COMx (RS-232C) Controller Link, SYSMAC NET, SYSMAC Link Ethernet Modem
Supported Software	<ul style="list-style-type: none"> MS Excel 97 and later MS Visual Basic 5 and later MS Visual C++ 6.0

Product Overview

	Description	Model code
Program¹	CX-Server Lite	CX-Server Lite
	CX-Server OPC	CX-Server OPC

1. Available in 3 and 10 user license for serial or network connection.

Functions

Program integration	<ul style="list-style-type: none"> Integration in VBA and Visual Basic via ActiveX® components Supports the use of ActiveX® components of other suppliers The interoperability of CX-Server OPC has been tested with numerous commercially available OPC clients
Application	Application-based display of PLC and OPC Server data with the features of MS Office products as well as VBA and Visual Basic
OPC functions	<ul style="list-style-type: none"> Synchronous or Asynchronous communication Reading from cache or device Subscription update rates starting from 100 milliseconds
Standard controls	<ul style="list-style-type: none"> 7 Segment- and Display control to display data in multiple formats Toggle button, Rotary Knob, Thumbwheel control and LED Indicator to write a value with a single click and to visualize the value at the same time Linear- and Rotational Gauge that can display data in a graphical way Data Logging, Timer and Linker controls to log data, trigger actions and connect third party ActiveX® controls

Computer Hardware and Software Requirements

Supported operating systems	Windows 95, 98, Me, 2000, XP and NT4.0 (Service Pack 5 and later)
Processor	Min. Pentium 200 MHz (Pentium II 400 MHz or higher recommended)
Memory requirements	Hard disk 30 MB free memory space
	RAM 64 MB min.
Screen	SVGA graphic, 800x600 or higher
Peripheral connections	COMx or network card for Ethernet or Controller Link, depending on the network used. Combinations are possible.

CX-Supervisor

PC based HMI

Process visualising with outstanding price/performance ratio

- Powerful functions can be used to create animated process images.
- Simple applications can be created rapidly with the aid of a large number of predefined functions and libraries, and even very complex applications can be generated with the powerful programming language (Scripts).
- A clear, straightforward structure minimises familiarisation times. Simple, intuitive handling and high user friendliness
- Versatile test and documentation facilities.
- OPC allows connections to Version 2 OPC Servers.
- Database support for SQL, ODBC, MS Access, MS Excel, dBase, CSV and more.
- Importing ActiveX® components makes it possible to create flexible applications and extend functionality.

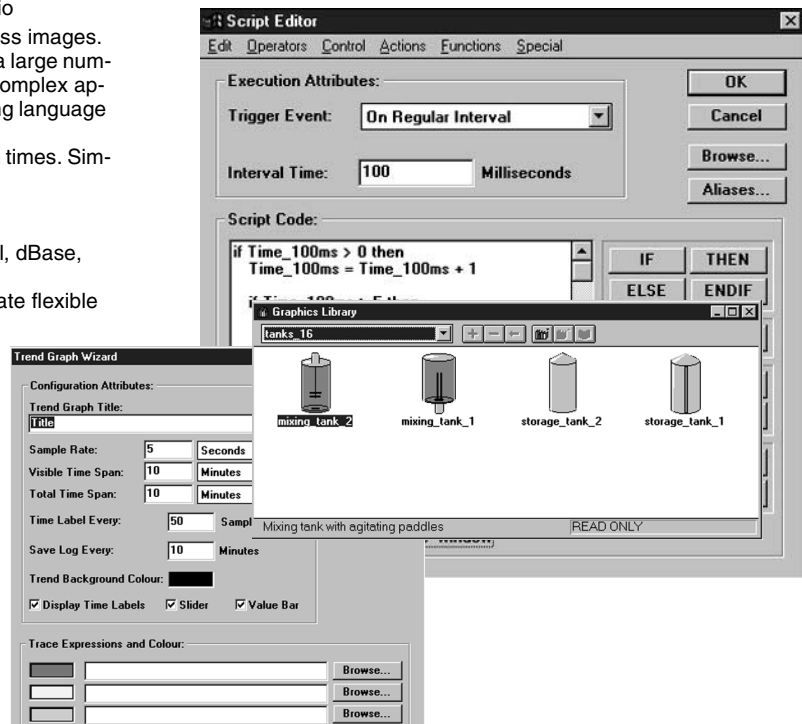

General Data

	Specification
Number of process points	8,000
Number of process images	No limit
Supported PLC systems	CS1, CJ1, SRM1, CPM, C20, CXxK, CXxH, C20P, CQM1, CQM1H, C200H/-HS/-HX/-HG/-HEC500, C1000H, C2000H, CV/CVM1
Supported OMRON controllers	E5AF-A/-H, E5EF-A/-H/-BA/-BAH, E5AJ-A, E5AK-A/-PRR, E5EK-A/-PRR, E5AX-LA/-MA/-PRR
Communication	<ul style="list-style-type: none"> • Peripheral port and SYSMAC NET Host Link interface via COMx • SYSMAC Link • Controller Link • Ethernet • Modem • DDE • OPC (Client) • ActiveX®

Product Overview

	Description	Model code
Program	Development version without Token	CX-SUPERVISOR
	Run-Time software with Token	CX-SUPERVISOR-RUN-TOK
	Run-Time software with Hardlock	CX-SUPERVISOR-RUN-HL
	Run-Time Token for the development version	CX-SUPERVISOR-TOK
	Run-Time Hardlock for the development version	CX-SUPERVISOR-HL
	Demo Version, 50 points, 2 hours	CX-SUPERVISOR-DEMO2

Functions

Programming types	<ul style="list-style-type: none"> • Predefined functions and graphic elements (libraries, animation editor) • Script language for solving complex control and data processing tasks • VBA and JAVA scripts can be imported • Active components can be incorporated with the ActiveX® property browser • HTML texts can be imported/displayed with Internet Explorer functionality (V.5.0 or higher)
Edit options	<p>Toolbars for creating and aligning graphic elements; libraries with a wide choice of predefined modules (Wizard function)</p> <p>Project Editor: Manages the process images you have created</p> <p>Points Editor: Creates and manages process points and internal variables</p> <p>Animation Editor: Assigns display variables, colour changes, movement etc. to graphic objects</p> <p>Alarm Editor: Assigns alarm limits/ranges to process points and internal variables</p> <p>Data block Editor: Creates and manages Data block files, online downloading to the PLC</p> <p>Script Editor: A powerful programming language with graphic and mathematical functions and commands for program control, file management etc.</p>
Mathematical functions	trigonometric, logarithmic and arithmetic functions
Math operators	+, -, *, /, %, =, <, >, <=, >=, !=, ==
Logical operations	AND, OR, NOT, TRUE, FALSE
Conditional program execution	IF-THEN-ELSE/ELSEIF, SELECT CASE
Display functions	Variables, text, date, time, comprehensive object animation options
Graphic functions	Straight line, rectangle, polygon, circle (outline or filled-in); bar chart, trend chart, scatter graph, display instruments, bitmap, OLE
Special functions	Keyboard input, write/read CSV file, program launch, Data block manager, alarms, password entry/verification with different authorisation levels, DDE/NetDDE/COM/DCOM/OPC-link to other WINDOWS applications, data logging, parameter transfer with ActiveX® events.
Documentation	<ul style="list-style-type: none"> • User-definable comments on all process points and internal variables • Printout of process images, variables lists, scripts etc.
Test options	Error Logger, Debugger

Computer hardware and software requirements

Supported operating systems	Windows 95, 98, Me, 2000, XP and NT4.0 (Service Pack 5 and later)
Processor	Min. Pentium with 200 MHz or higher
Memory requirements	Hard disk 40 MB of free memory space
	RAM Min. 64 MB, 128 MB recommended
Screen	VGA graphic, SVGA graphic with 1024x768 or higher recommended
Peripheral connections	<ul style="list-style-type: none"> • 1.44 MB disk drive, COMx serial port, mouse • Parallel printer port (any WINDOWS supported printer)

Ordering Information

PLC programming	CX-Programmer single user	WS02-CXPC1-E-V
	CX-Programmer 3 user	WS02-CXPC1-E03-V
	CX-Programmer 10 user	WS02-CXPC1-E10-V
	CX-Programmer CPM/SRM user	WS02-CXPC1-EJ-V
	CX-Programmer single upgrade for Syswin/CXP V2.x	WS02-CXPC1-EUP-V
	CX-Programmer 3 upgrade for Syswin/CXP V2.x	WS02-CXPC1-EUP03-V
	CX-Programmer 10 upgrade for Syswin/CXP V2.x	WS02-CXPC1-EUP10-V
	CX-Programmer CPM/SRM upgrade for Syswin/CXP V2.x	WS02-CXPC1-EUPJ-V
	CX-Programmer V3.* update (no license code)	WS02-CXPC1-EUPL-EV
Configuration	CX-Simulator	WS02-SIMC1-E
	CX-Protocol	WS02-PSTC1-E
	CX-Motion	WS02-MCTC1-EV
	CX-Position	WS02-NCTC1-E
	CX-Process Tool	WS02-LCTC1-EV
	CX-Process Monitor	WS02-LCTK1-EL01
	CX-Process Analog I/O Unit Support Software	WS02-PUTC1-E
Fieldbus	DeviceNet Configurator	WS02-CFDC1-E/3G8E2-DRM21-E
	NX-Server	WS02-NXD1-E
	CX-PROFIBUS Configurator	WS02-PDC3
Visualization	NS-Designer	NS-NSDC1-EV
	NS Face Plate Auto Builder	WS02-NSFC1-E
	NT-Programming	NT-Shell-
	CX-Server Lite ActiveX single RS232-C/RS422 serial user	CX-LITE-serial-EV
	CX-Server Lite ActiveX 03 RS232-C/RS422 serial users	CX-LITE-serial-03-EV
	CX-Server Lite ActiveX 10 RS232-C/RS422 serial users	CX-LITE-serial-10-EV
	CX-Server Lite ActiveX single Network (Ethernet Controllerlink Sysmaclink) user	CX-LITE-EV
	CX-Server Lite ActiveX 03 Network (Ethernet Controllerlink Sysmaclink) users	CX-LITE-03-EV
	CX-Server Lite ActiveX 10 Network (Ethernet Controllerlink Sysmaclink) users	CX-LITE-10-EV
	CX-Server Lite ActiveX single RS232-C/RS422 serial 2 hour time limit	CX-LITE-DEMO-EV
	CX-Server OPC single RS232-C/RS422 serial user	CX-OPC-serial-EV
	CX-Server OPC 03 RS232-C/RS422 serial users	CX-OPC-serial-03-EV
	CX-Server OPC 10 RS232-C/RS422 serial users	CX-OPC-serial-10-EV
	CX-Server OPC single Network (Ethernet Controllerlink Sysmaclink) user	CX-OPC-EV
	CX-Server OPC 03 Network (Ethernet Controllerlink Sysmaclink) users	CX-OPC-03-EV
	CX-Server OPC 10 Network (Ethernet Controllerlink Sysmaclink) users	CX-OPC-10-EV
	CX-Server OPC single RS232-C/RS422 serial 2 hour time limit	CX-OPC-DEMO-EV
	PC based visaulization development package only	CX-SUPERVISOR-
	Runtime package + token	CX-SUPERVISOR-RUN-TOK-
	Runtime package hardlock	CX-SUPERVISOR- RUN-HL-
	Runtime Token only	CX-SUPERVISOR-TOK-
	Runtime Hardlock only	CX-SUPERVISOR-HL-
	Demo for development + 2 hour runtime	CX-SUPERVISOR-DEMO2-