

VZ

V1000

More performance & Quality in less space

- Current vector control
- High starting torque (200% / 0.5 Hz)
- 1:100 speed control range
- Double rating ND 120%/1min and HD 150%/1 min
- IM&PM motor control
- Online Tuning
- Low-noise Low carrier technology
- 10 years lifetime design
- Built-in filter
- Screw-less terminals
- Control Terminals with memory backup
- 24 VDC control board power supply option
- Fieldbus communications: Modbus, Profibus, CanOpen, DeviceNet, Lonworks, CompoNet, Ethernet
- Safety embedded (EN954-1 safety cat. 3)
- CE, UL, cUL and TUV

Ratings

- 200 V Class single-phase 0.1 to 4 kW
- 200 V Class three-phase 0.1 to 15 kW
- 400 V Class three-phase 0.2 to 15 kW



System configuration

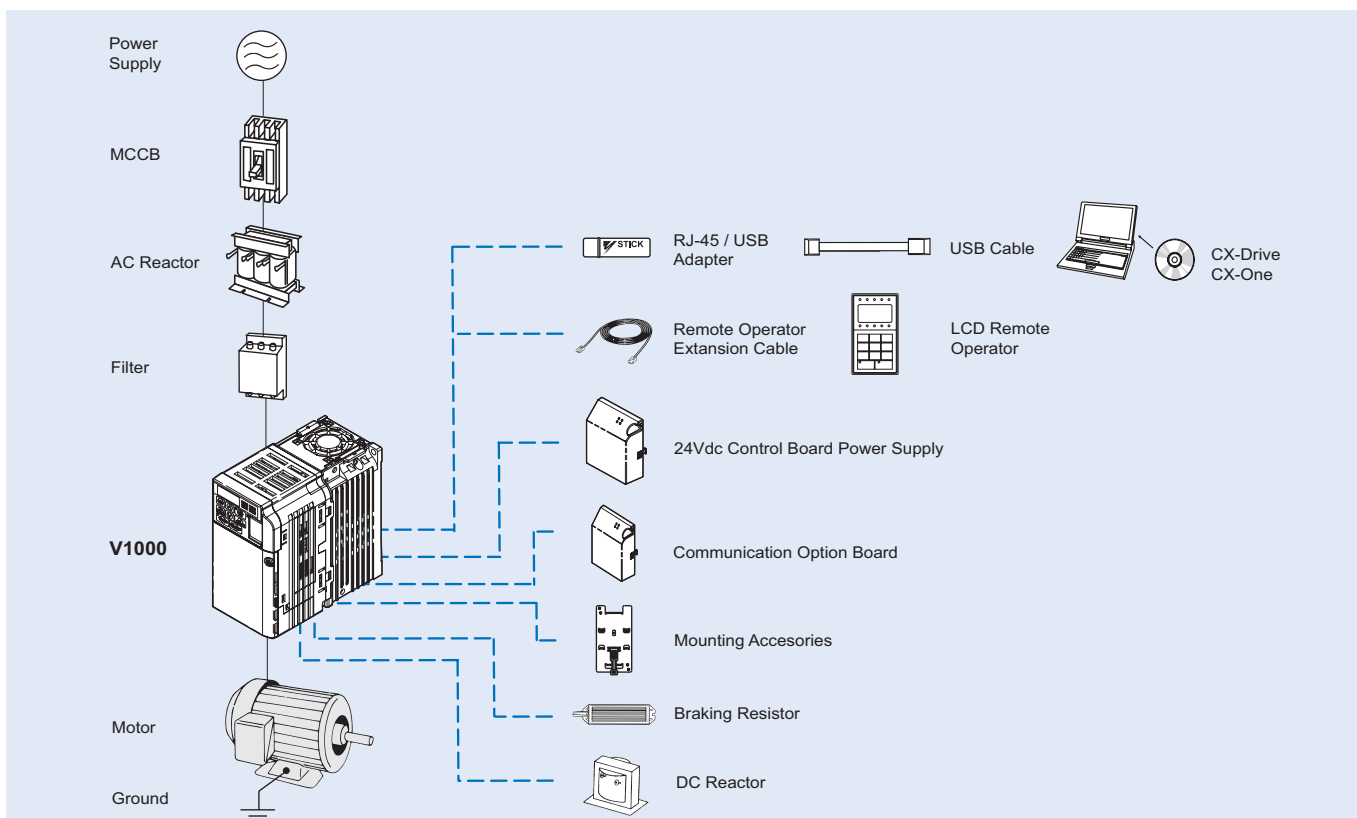

Specifications

Type designation

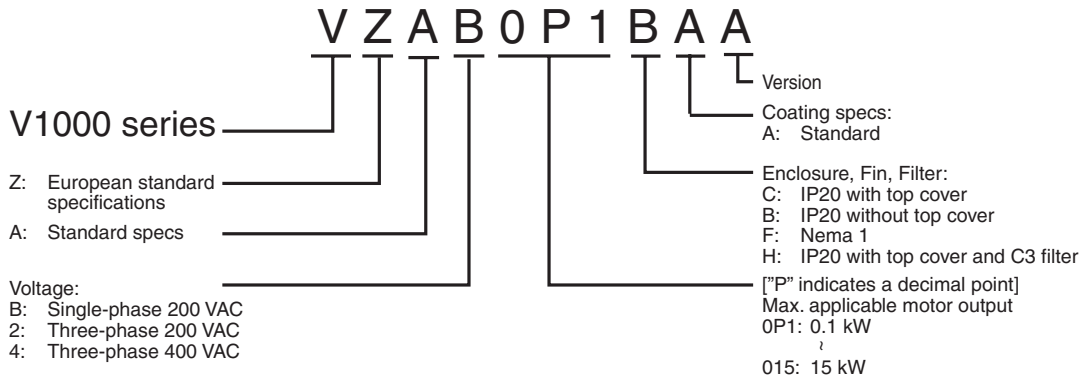

200 V class

Single-phase: VZ-□		B0P1	B0P2	B0P4	B0P7	B1P5	B2P2	B4P0	-	-	-	-
Three-phase: VZ-□		20P1	20P2	20P4	20P7	21P5	22P2	24P0	25P5	27P5	2011	2015
Motor kW ¹	For HD setting	0.12	0.25	0.4	0.75	1.5	2.2	4.0	5.5	7.5	11	15
	For ND setting	0.18	0.37	0.75	1.1	2.2	3.0	5.5	7.5	11	15	18.5
Output characteristics	Inverter capacity kVA	0.3	0.6	1.1	1.9	3.0	4.2	6.7	9.5	13	18	23
	Rated output current (A) at HD	0.8	1.6	3.0	5.0	8.0	11.0	17.5	25.0	33.0	47.0	60.0
	Rated output current (A) at ND	1.2	1.9	3.5	6.0	9.6	12.0	21.0	30.0	40.0	56.0	69.0
	Max. output voltage	Proportional to input voltage: 0..240 V										
	Max. output frequency	400 Hz										
Power supply	Rated input voltage and frequency	Single-phase 200..240 V 50/60 Hz 3-phase 200..240 V 50/60 Hz										
	Allowable voltage fluctuation	-15%..+10%										
	Allowable frequency fluctuation	+5%										

1. Based on a standard 4-pole motor for maximum applicable motor output:
 Heavy Duty (HD) mode with a 150% overload capacity
 Normal Duty (ND) mode with a 120% overload capacity

400 V class

Three-phase: VZ-□		40P2	40P4	40P7	41P5	42P2	43P0	44P0	45P5	47P5	4011	4015
Motor kW ¹	For HD setting	0.2	0.4	0.75	1.5	2.2	3.0	4.0	5.5	7.5	11	15
	For ND setting	0.37	0.75	1.5	2.2	3.0	3.7	5.5	7.5	11	15	18.5
Output characteristics	Inverter capacity kVA	0.9	1.4	2.6	3.7	4.2	5.5	7.2	9.2	14.8	18	24
	Rated output current (A) at HD	1.2	1.8	3.4	4.8	5.5	7.2	9.2	14.8	18.0	24	31
	Rated output current (A) at ND	1.2	2.1	4.1	5.4	6.9	8.8	11.1	17.5	23	31	38
	Max. output voltage	0..480V (proportional to input voltage)										
	Max. output frequency	400 Hz										
Power supply	Rated input voltage and frequency	3-phase 380..480 VAC, 50/60 Hz										
	Allowable voltage fluctuation	-15%..+10%										
	Allowable frequency fluctuation	+5%										

1. Based on a standard 4-pole motor for maximum applicable motor output:
 Heavy Duty (HD) mode with a 150% overload capacity
 Normal Duty (ND) mode with a 120% overload capacity

Specifications

Common specifications

Model number VZ-□	Specifications	
Control functions	Control methods	Sine wave PWM (V/f control, sensorless current vector control)
	Output frequency range	0.1..400 Hz
	Frequency tolerance	Digital set value: ±0.01% (-10..+50 °C)
		Analogue set value: ±0.1% (25 ±10 °C)
	Resolution of frequency set value	Digital set value: 0.01 Hz (<100 Hz), 0.1 Hz (>100 Hz)
		Analogue set value: 1/1000 of maximum frequency
	Resolution of output frequency	0.01 Hz
	Overload capability	Heavy duty use: 150% rated output current for one minute Normal duty use: 120% rated output current for one minute
	Frequency set value	0..10 V (20 kΩ), 4..20 mA (250 Ω), 0..20 mA (250 Ω) Pulse train input, frequency setting value (selectable)
	Braking torque (short term peak torque)	Short-term average deceleration torque: 150% (up 1.5 kW), 100% (for 1.5 kW), 50% (for 2.2 kW), 20% (for bigger size) Continuous regenerative torque: Approx 20% (125% with optional braking resistor, 10%ED, 10 s, braking transistor built in)
V/f Characteristics	Possible to program any V/f pattern	
Functionality	Inputs signals	Seven of the following input signals are selectable: Forward/reverse run (3-wire sequence), fault reset, external fault (NO/NC contact input), multi-step speed operation, Jog command, accel/decel time select, external baseblock, speed search command, UP/DOWN command, accel/decel hold command, LOCAL/REMOTE selection, communication/control circuit terminal selection, emergency stop fault, emergency stop alarm, self test
	Output signals	Following output signals are selectable (NO/NC contact output, 2 photo-coupler outputs): Fault, running, zero speed, speed agree, frequency detection (output frequency ≤ or ≥ set value), during overtorque detection, minor error, during baseblock, operation mode, inverter run ready, during fault retry, during undervoltage detection, reverse running, during speed search, data output through communication.
	Standard functions	Open-loop vector control, full-range automatic torque boost, slip compensation, 17-step speed operation (max.), restart after momentary power loss, DC injection braking current at stop/start (50% of inverter rated current, 0.5 sec, or less), frequency reference bias/gain, MEMOBUS communications (RS-485/422, max. 115K bps), fault retry, speed search, frequency upper/lower limit setting, overtorque detection, frequency jump, accel/decel time switch, accel/decel prohibited, S-curve accel/decel, PID control, energy-saving control, constant copy.
	Analogue inputs	2 analogue inputs, 0..10 V, 4..20 mA, 0..20 mA
	Braking/acceleration times	0.01..6000 s
	Display	Optionally frequency, current or set value Error and status LED
Protection functions	Motor overload protection	Electronic thermal overload relay
	Instantaneous overcurrent	Motor coasts to a stop at approx. 250% of inverter rated current
	Overload	Heavy Duty: Motor coasts to a stop after 1 minute at 150% of inverter rated output current Normal Duty: Motor coasts to a stop after 1 minute at 120% of inverter rated output current
	Overvoltage	Motor coasts to a stop if DC bus voltage exceed 410 V (double for 400 V class)
	Undervoltage	Stops when DC bus voltage is approx. 190 V or less (double for 400 V class) (approx. 150 V or less for single-phase series)
	Momentary power loss	Following items are selectable: not provided (stop if power loss is 15 ms or longer), continuous operation if power loss is approx. 0.5 s or shorter, continuous operation
	Cooling fin overheat	Protected by thermister
	Stall prevention level	Stall prevention during acceleration/deceleration and constant speed operation
	Ground fault	Protected by electronic circuit (operation level is approx. 250% of rated output current)
Power charge indication	Indicates until the main circuit voltage reaches 50 V.	
Ambient conditions	Degree of protection	IP20, NEMA1
	Cooling	Cooling fan is provided for 200 V, 0.75 kW (1HP) (3/single-phase) 400 V, 1.5 kW (2HP) (3-phase), others are self-cooling
	Ambient humidity	95% RH or less (without condensation)
	Storage temperature	-20 °C..+60 °C (short-term temperature during transportation)
	Installation	Indoor (no corrosive gas, dust, etc.)
	Installation height	Max. 1000 m
Vibration	Up to 1 G at 10 to less than 20 Hz, Up to 0.65 G at 20 to 50 Hz	

Dimensions

IP 20 type 0.1 to 4 kW

Figure 1

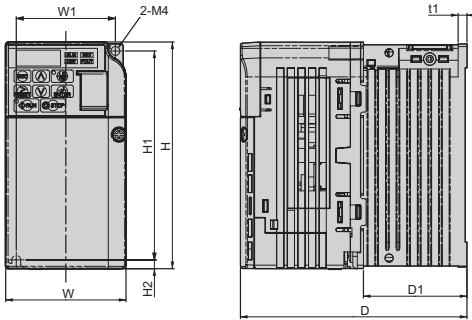
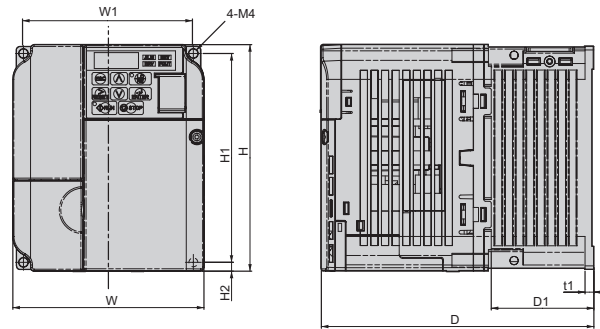
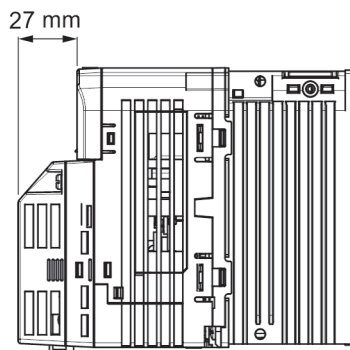

Figure 2



Voltage class	Max. applicable motor output kW	Inverter model VZA	Figure	Dimensions in mm										Weight			
				W1	H1	W	H	D	t1	H2	D1	H3	H4				
Single-phase 200 V	0.12	B0P1	1	56	118	68	128	76	3	5	6.5	-	-	0.6			
	0.25	B0P2						108	5					38.5	0.7		
	0.55	B0P4						137.5	5					58	1.0		
	1.1	B0P7	2	96	108	140	154	5	5	58	-	-	1.5				
	1.5	B1P5					163						1.5				
	2.2	B2P2					65						2.1				
	4.0	B4P0	Under development										2.1				
Three-phase 200 V	0.12	20P1	1	56	118	68	128	76	3	5	6.5	-	-	0.6			
	0.25	20P2						108	5					38.5	0.6		
	0.55	20P4						128	5					58	0.9		
	1.1	20P7	2	96	108	140	129	5	5	58	-	-	1.1				
	1.5	21P5					137.5						1.3				
	2.2	22P2					143						1.4				
	4.0	24P0	3	128	140	254	140	-	6	55	13	6.2	-	2.1			
	5.5	25P5												7	75	15	3.8
	7.5	27P5												8	78	15	3.8
	11	2011												7	78	15	5.5
15	2015	192	336	220	358	187	7	78	15	7.2	9.2						
Three-phase 400 V	0.37	40P2	2	96	118	108	128	81	5	5	10	-	-	0.8			
	0.55	40P4						99						28	1.0		
	1.1	40P7						137.5						58	1.4		
	1.5	41P5						154						58	1.5		
	2.2	42P2						143						65	1.5		
	3.0	43P0	3	128	140	254	140	-	6	55	13	6	-	2.1			
	4.0	44P0												7	75	15	3.8
	5.5	45P5												8	75	15	3.8
	7.5	47P5												143	15	6	5.2
	11	4011												163	15	6	5.2
15	4015	163	15	6	5.5												

V1000 + Option board



Built-in Filter Dimensions

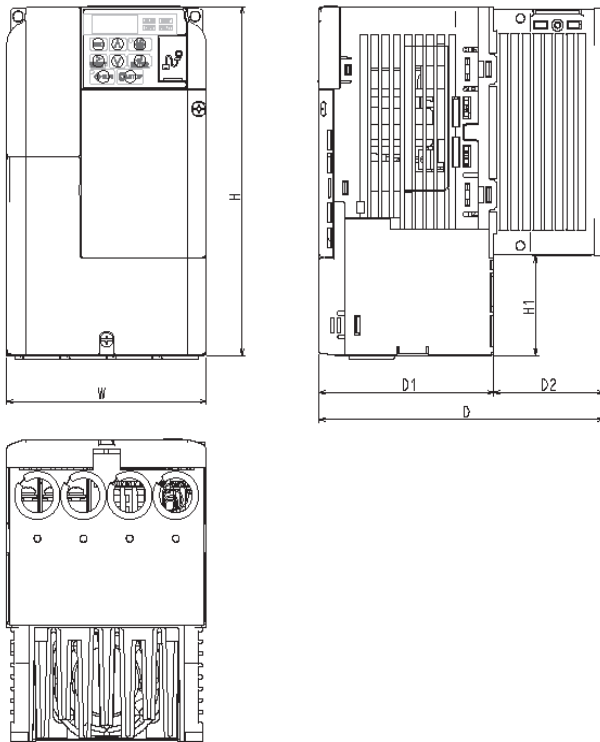

VZA-	Dimensions in mm					
	W	H	H1	D1	D2	D
B0P1	68	178	50	69.5	6.5	76
B0P2				79.5	38.5	118
B0P4	77.9			59.6	137.5	
B0P7	89.4			64.6	154	
B1P5	108					
B2P2	140	183	55	96.4	66.6	163
B4P0	Under development					
40P2	108	178	50	69.4	11.6	81
40P4					29.6	99
40P7				77.9		137.5
41P5						
42P2				94.4	59.6	154
43P0						
44P0	140	183	55	76.4	66.6	143
45P5	Under development					
47P5						
4011						
4015						

Schaffner footprint Filters

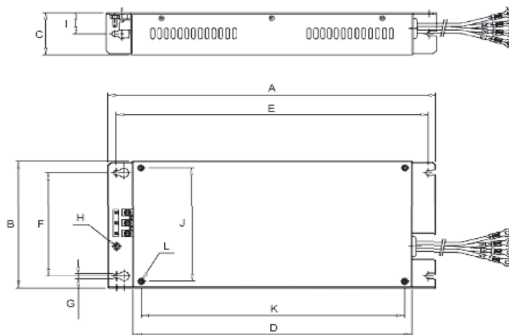

Schaffner model		Dimensions											
		A	B	C	D	E	F	G	H	I	J	K	L
3x200 V	A1000-FIV2010-SE	194	82	50	160	181	62	5.3	M5	25	56	118	M4
	A1000-FIV2020-SE	169	111	50	135	156	91	5.5	M5	25	96	118	M4
	A1000-FIV2030-SE	174	144	50	135	161	120	5.3	M5	25	128	118	M4
	A1000-FIV2050-SE	Under development											
	A1000-FIV2100-SE	Under development											
1x200 V	A1000-FIV1010-SE	169	71	45	135	156	51	5.3	M5	22	56	118	M4
	A1000-FIV1020-SE	169	111	50	135	156	91	5.3	M5	25	96	118	M4
	A1000-FIV1030-SE	174	144	50	135	161	120	5.3	M5	25	128	118	M4
	A1000-FIV1040-SE	174	144	50	135	161	150	5	M5	25	158	118	M4
3x400 V	A1000-FIV3005-SE	169	111	45	135	156	91	5.3	M5	22	96	118	M4
	A1000-FIV3010-SE	169	111	45	135	156	91	5.3	M5	22	96	118	M4
	A1000-FIV3020-SE	174	144	50	135	161	120	5	M5	25	128	118	M4
	A1000-FIV3030-SE	304	184	56	264	288	150	6	M5	28	164	244	M5
	A1000-FIV3050-SE	Under development											

Rasmi footprint Filters

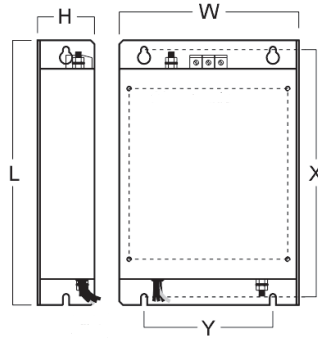

Rasmi model		Dimensions						Weight
		W	H	L	X	Y	M	KG
3x200 V	A1000-FIV2010-RE	82	50	194	181	62	M4	0.8
	A1000-FIV2020-RE	111	50	194	181	62	M4	1.1
	A1000-FIV2030-RE	144	50	174	161	120	M4	1.3
	A1000-FIV2060-RE	150	52	320	290	122	M5	2.4
1x200 V	A1000-FIV2100-RE	188	62	362	330	160	M5	4.2
	A1000-FIV1010-RE	71	45	169	156	51	M4	0.6
	A1000-FIV1020-RE	111	50	169	156	91	M4	1.0
	A1000-FIV1030-RE	144	50	174	161	120	M4	5.3
3x400 V	A1000-FIV1040-RE	Under development						
	A1000-FIV3005-RE	111	45	169	156	91	M4	1.1
	A1000-FIV3010-RE	111	45	169	156	91	M4	1.1
	A1000-FIV3020-RE	144	50	174	161	120	M4	1.3
	A1000-FIV3030-RE	150	52	306	290	122	M5	2.1
	A1000-FIV3050-RE	182	62	357	330	160	M5	2.9

DIN rail mounting bracket

EZZ08122A

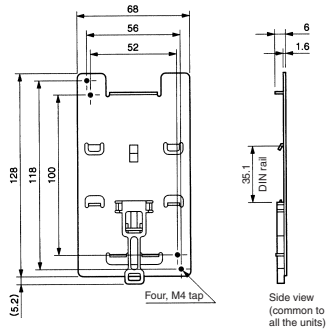

EZZ08122B

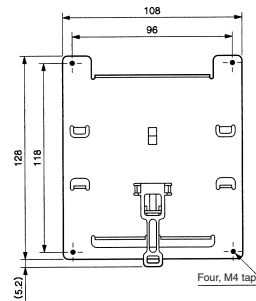

EZZ08122C

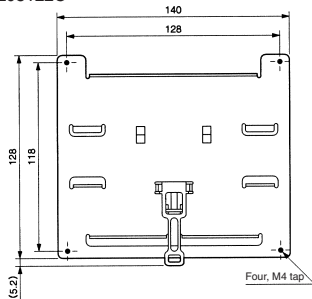

EZZ08122D

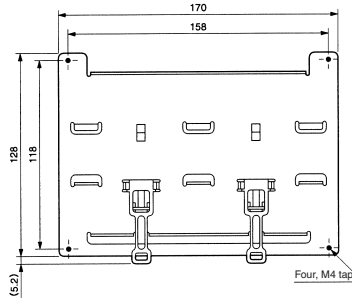

	Inverter	DIN rail mounting bracket
3-phase 200 VAC	VZ - 20P1/ 20P2 / 20P4/ 20P7	EZZ08122A
	VZ - 21P5/ 22P2	EZZ08122B
	VZ - 24P0	EZZ08122C
Single-phase 200 VAC	VZ - B0P1/ B0P2/ B0P4	EZZ08122A
	VZ - B0P7/ B1P5	EZZ08122B
	VZ - B2P2	EZZ08122C
	VZ - B4P0	EZZ08122D
3-phase 400 VAC	VZ - 40P2/ 40P4/ 40P7/ 41P5/ 42P2	EZZ08122B
	VZ - 44P0	EZZ08122C

Heatsink attachment and Panel cut dimensions

Heatsink External Mounting Attachment

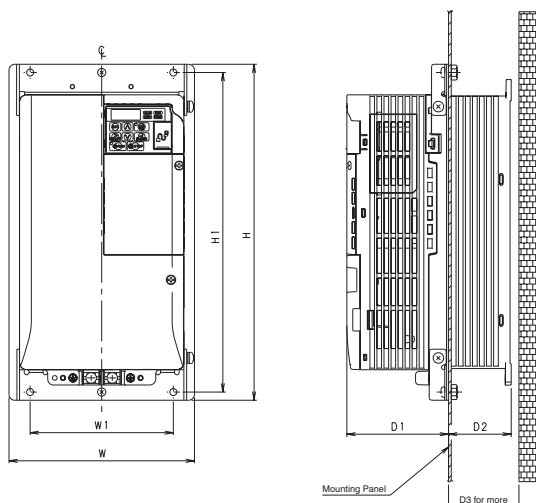

Panel Cut for External Mounting of Cooling Fin (Heatsink)

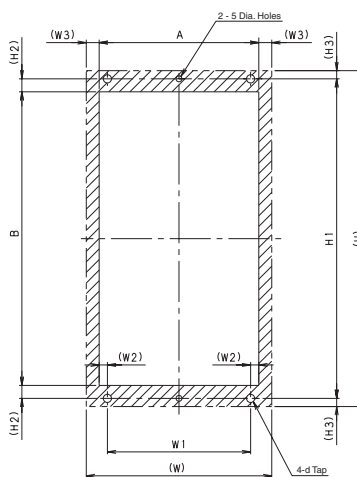
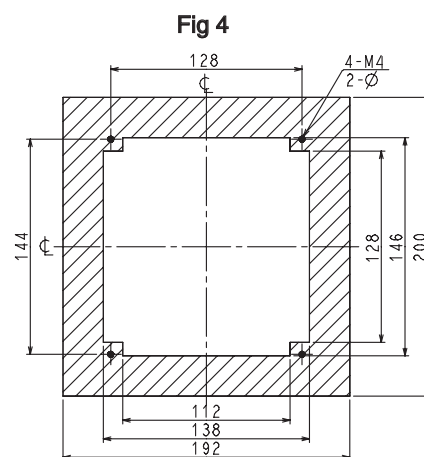
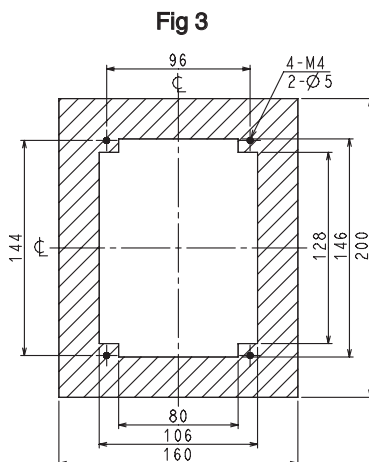
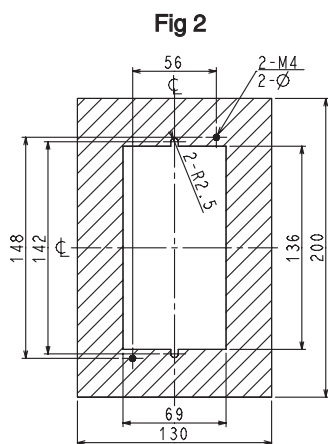
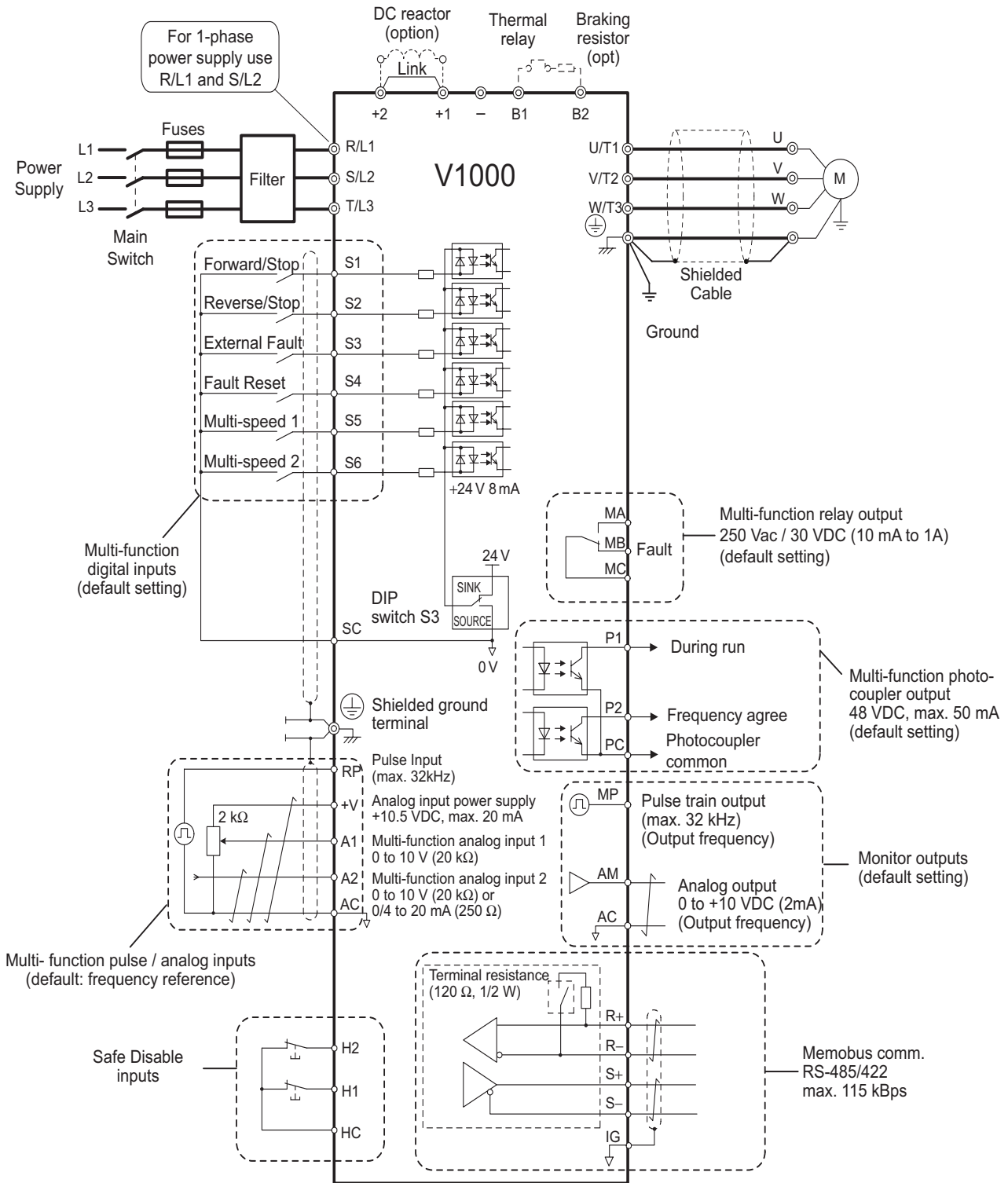

Fig 1

VZA	Reference	Frame							Panel Cutting							
		W	H	W1	H1	D1	D2	D3	Fig	(W2)	(W3)	(H2)	(H3)	A	B	
3x200V	20P1	100-034-075	68	128	56	118	69.2	12	30	2	-					
	20P2							42	50							
	20P4							62	70							
	20P7	100-034-077	108	96	71	79.5	58	70	3	-						
	21P5															
	22P2															
	24P0	100-034-079	140	128	86.5	53.5	60	4	-							
	25P5	100-036-300	158	286	122	272	86.6	53.4	60	1	9	9	8.5	7	140	255
	27P5		10	10.5	10.5	9	180	287								
2011	100-036-301	198	322	160	308	89.6	73.4	80	14		10.5	10.5	9	220	341	
2015	100-036-302	241	380	192	362	110.6	76.4	85	-							
1X200V	B0P1	100-034-075	68	128	56	118	69.2	12	30	2	-					
	B0P2															
	B0P4							79.2	42							50
	B0P7	100-035-418	108	96	79.5	96	58	70	3	-						
	B1P5															
	B2P2	100-034-079	140	128	98	65	4	-								
B4P0	100-034-080	Under development														
3X400V	40P2	100-034-078	108	128	96	118	71	13.2	30	3	-					
	40P4						28	40								
	40P7						79.5	58	70							
	41P5	100-034-079	140	128	78	65	4	-								
	42P2															
	43P0	100-034-080	158	286	122	272	86.6	53.4	60	1	9	9	8.5	7	140	255
	44P0										10	10.5	10.5	9	180	287
	45P5										73.4	80	-			
	47P5	100-036-300	198	322	160	308	86.6	53.4	60	1	9	9	8.5	7	140	255
	4011										10	10.5	10.5	9	180	287
4015	100-036-301	-														



Standard connections



Symbols:

⊕ Use twisted pair cables

⊙ Indicates a main circuit terminal

⊕ Use shielded twisted pair cables

○ Indicates a control circuit terminal.

Main circuit

Terminal	Name	Function (signal level)
R/L1, S/L2, T/L3	Main circuit power supply input	Used to connect line power to the drive. Drives with single-phase 200 V input power use only terminals R/L1 and S/L2 (T/L3 is not connected to anything)
U/T1, V/T2, W/T3	Inverter output	Used to connect the motor
B1, B2	Braking resistor connection	Available for connecting a braking resistor or the braking resistor unit option.
+2, +1	DC reactor connection	Remove the short bar between +2 and +1 when connecting DC reactor (option)
+1, -	DC power supply input	For power supply input (+1: positive electrode; - : negative electrode)*
⊕	Grounding	For grounding (grounding should conform to the local grounding code.)

Control Circuit

Type	No.	Signal name	Function	Signal level
Digital input signals	S1	Multi-function input selection 1	Factory setting: runs when CLOSED, stops when OPEN.	24 VDC, 8 mA photocoupler insulation
	S2	Multi-function input selection 2	Factory setting: runs when CLOSED, stops when OPEN.	
	S3	Multi-function input selection 3	Factory setting: External Fault (N.O.)	
	S4	Multi-function input selection 4	Factory setting: Fault reset	
	S5	Multi-function input selection 5	Factory setting: Multi-step speed cmd 1	
	S6	Multi-function input selection 6	Factory setting: Multi-step speed cmd 2	
	SC	Multi-function input selection Common	Common for control signal	
Analog input signals	RP	Main Speed Cmd Pulse Train Input	32 kHz max.	
	FS	Power Supply for Frequency Setting	+10 V (allowable max current 20 mA)	
	FR1	Main Speed Freq Ref	Voltage input or current input	
	FR2		0 to +10 VDC (20 k Ω) (resolution 1/1000) 4 to 20 mA (250 Ω) or 0 to 20 mA (250 Ω) Resolution: 1/500	
FC	Frequency reference common	0 V		
Fast Stop Cmd	HC	Power Supply Fast Stop Cmd	+24 V (max allowable current 10 mA)	
	H1	Special Digital input	Open: Fast Stop Closed: Normal Operation	
	H2	Special Digital input		
Digital output signals	MA	NO contact output	Factory setting: "fault"	Contact capacity 250 VAC, 1 A or less 30 VDC, 1 A or less
	MB	NC Output		
	MC	Relay Output common		
	P1	Photocoupler output 1	Factory setting: During run	Photocoupler output: +48 VDC, 50 mA or less
	P2	Photocoupler output 2	Factory setting: Frequency Agree	
	PC	Photocoupler output common	0 V	
Analog output signals	PM	Pulse train Output	max 33 kHz	
	AM	Analog monitor output	Factory setting: "output frequency" 0 to +10 V output Resolution: 1/1000	0 to 10 V 2 mA or less Resolution: 8 bits
	AC	Analog monitor common	0 V	
RS-485/422	R+	Communication input (+)	For MEMOBUS communication operation by RS-485 or RS-422 communication is available.	RS-485/422 MEMOBUS protocol
	R-	Communication input (-)		
	S+	Communication output (+)		
	S-	Communication output (-)		

a: Space required differs by model:
 Up to 3.7 kW: minimum 30 mm
 5.5 kW and above: minimum 50 mm

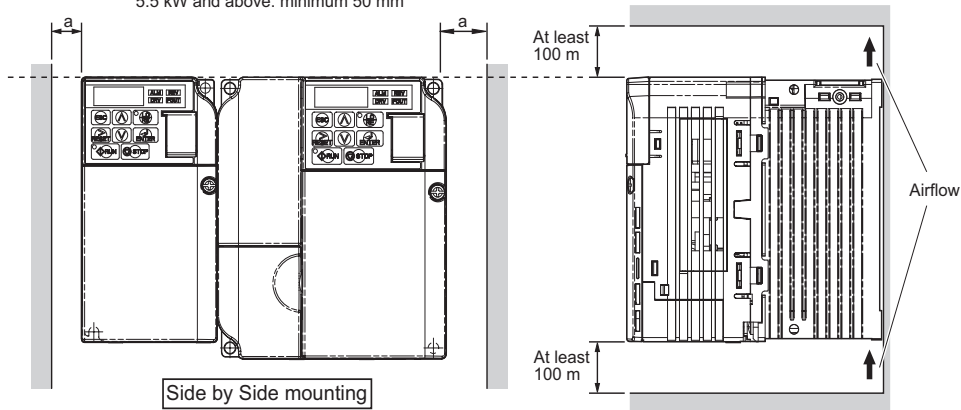

Inverter heat loss

Three-phase 200 V class

Model VZ		20P1	20P2	20P4	20P7	21P5	22P2	24P0	25P5	27P5	2011	2015
Inverter capacity kVA		0.3	0.6	1.1	1.9	3.0	4.2	6.7	9.5	13	18	23
Rated current (A) at HD		0.8	1.6	3	5	8	11	17.5	25	33	47.0	60.0
Rated current (A) at ND		1.2	1.9	3.5	6.0	9.6	12.0	21.0	30.0	40.0	56.0	69.0
Heat loss W HD	Fin	4.3	7.9	16.1	27.4	54.8	70.7	110.5	231.5	239.5	347.6	437.7
	Inside unit	7.3	8.8	11.5	15.9	23.8	30.0	43.3	72.2	81.8	117.6	151.4
	Total heat loss	11.6	16.7	27.7	43.3	78.6	100.6	153.8	303.7	321.3	465.2	589.1
Heat loss W ND	Fin	4.7	7.2	14.0	35.6	48.6	57.9	93.3	236.8	258.8	342.8	448.5
	Inside unit	7.9	9.4	13.4	16.9	25.0	29.6	45.0	87.2	11.4	149.1	182.2
	Total heat loss	12.6	16.6	28.5	43.1	73.6	87.5	138.2	324.0	370.3	491.9	630.7
Cooling Method		Self Cooled					Fan Cooled					

Single-phase 200 V class

Model VZ		B0P1	B0P2	B0P4	B0P7	B1P5	B2P2	B4P0
Inverter capacity kVA		0.3	0.6	1.1	1.9	3.0	4.2	6.7
Rated current (A) at HD		0.8	1.6	3	5	8	11	17.5
Rated current (A) at ND		1.2	1.9	3.5	6.0	9.6	12.0	21.0
Heat loss W HD	Fin	4.3	7.9	16.1	42.5	54.8	70.7	110.5
	Inside unit	7.4	8.9	11.5	19.0	25.9	34.1	51.4
	Total heat loss	11.7	16.7	27.7	61.5	80.7	104.8	161.9
Heat loss W ND	Fin	4.7	7.2	15.1	26.2	48.6	57.9	93.3
	Inside unit	8.4	9.6	14.3	20.8	29.0	36.3	58.5
	Total heat loss	13.1	16.8	28.3	56.5	77.6	94.2	151.8
Cooling Method		Self Cooled				Fan Cooled		

Three-phase 400 V class

Model VZ		40P2	40P4	40P7	41P5	42P2	43P0	44P0	45P5	47P5	4011	4015
Inverter capacity kVA		0.9	1.4	2.6	3.7	4.2	5.5	7.2	9.2	14.8	18	24
Rated current (A) at HD		1.2	1.8	3.4	4.8	5.5	7.2	9.2	14.8	18.0	24	31
Rated current (A) at ND		1.2	2.1	4.1	5.4	6.9	8.8	11.1	17.5	23	31	38
Heat loss W HD	Fin	19.2	28.9	42.3	70.7	81.0	84.6	107.2	166.0	207.1	266.9	319.1
	Inside unit	11.4	14.9	17.9	26.2	30.7	32.9	41.5	62.7	78.1	105.9	126.6
	Total heat loss	30.6	43.7	60.2	96.9	111.7	117.5	148.7	228.7	285.2	372.7	445.8
Heat loss W ND	Fin	8.2	15.5	26.4	37.5	49.7	55.7	71.9	170.3	199.5	268.6	298.7
	Inside unit	9.2	13.1	15.8	20.0	26.3	29.4	43.6	78.1	105.3	142.8	152.2
	Total heat loss	17.4	28.6	42.2	57.5	76.0	85.1	115.5	248.4	304.8	411.4	450.9
Cooling Method		Self Cooled					Fan Cooled					

Connections for braking resistor

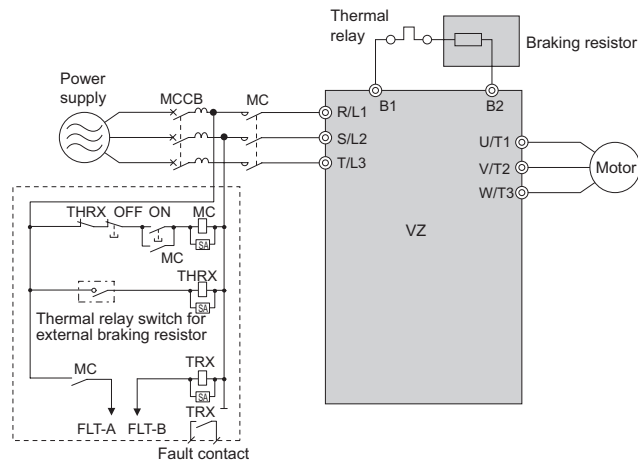

AC reactor

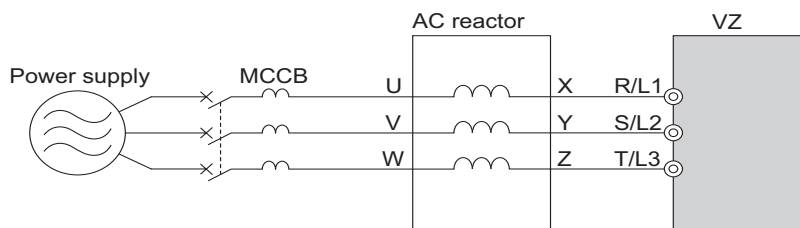

200 V class			400 V class		
Max. applicable motor output kW	Current value A	Inductance mH	Max. applicable motor output kW	Current value A	Inductance mH
0.12	2.0	2.0			
0.25	2.0	2.0			
0.55	2.5	4.2	0.2	1.3	18.0
1.1	5	2.1	0.4	2.5	8.4
1.5	10	1.1	1.5	5	4.2
2.2	15	0.71	2.2	7.5	3.6
4.0	20	0.53	4.0	10	2.2
5.5	30	0.35	5.5	15	1.42
7.5	40	0.265	7.5	20	1.06
11	60	0.18	11	30	0.7
15	80	0.13	15	40	0.53

DC reactor

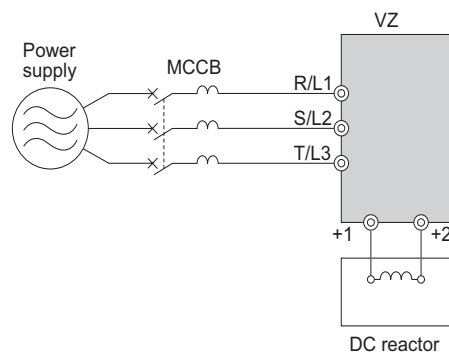

200 V class			400 V class		
Max. applicable motor output kW	Current value A	Inductance mH	Max. applicable motor output kW	Current value A	Inductance mH
0.12					
0.25					
0.55			0.2		
1.1			0.4	3.2	28
1.5			0.75		
2.2	18	3	1.5	5.7	11
4.0			2.2		
5.5			4.0	12	6.3
7.5	36	1	5.5	23	3.6
11			7.5		
15	72	0.5	11	33	1.9
			15		

V1000 safe stop application using OMRON G9SB safety relay unit complies to safety category 3 according EN 954-1 / Stop category 0 according EN60204

Ensure V1000 and safety relay are mounted in the same cabinet to exclude cross circuit between H1 and H2

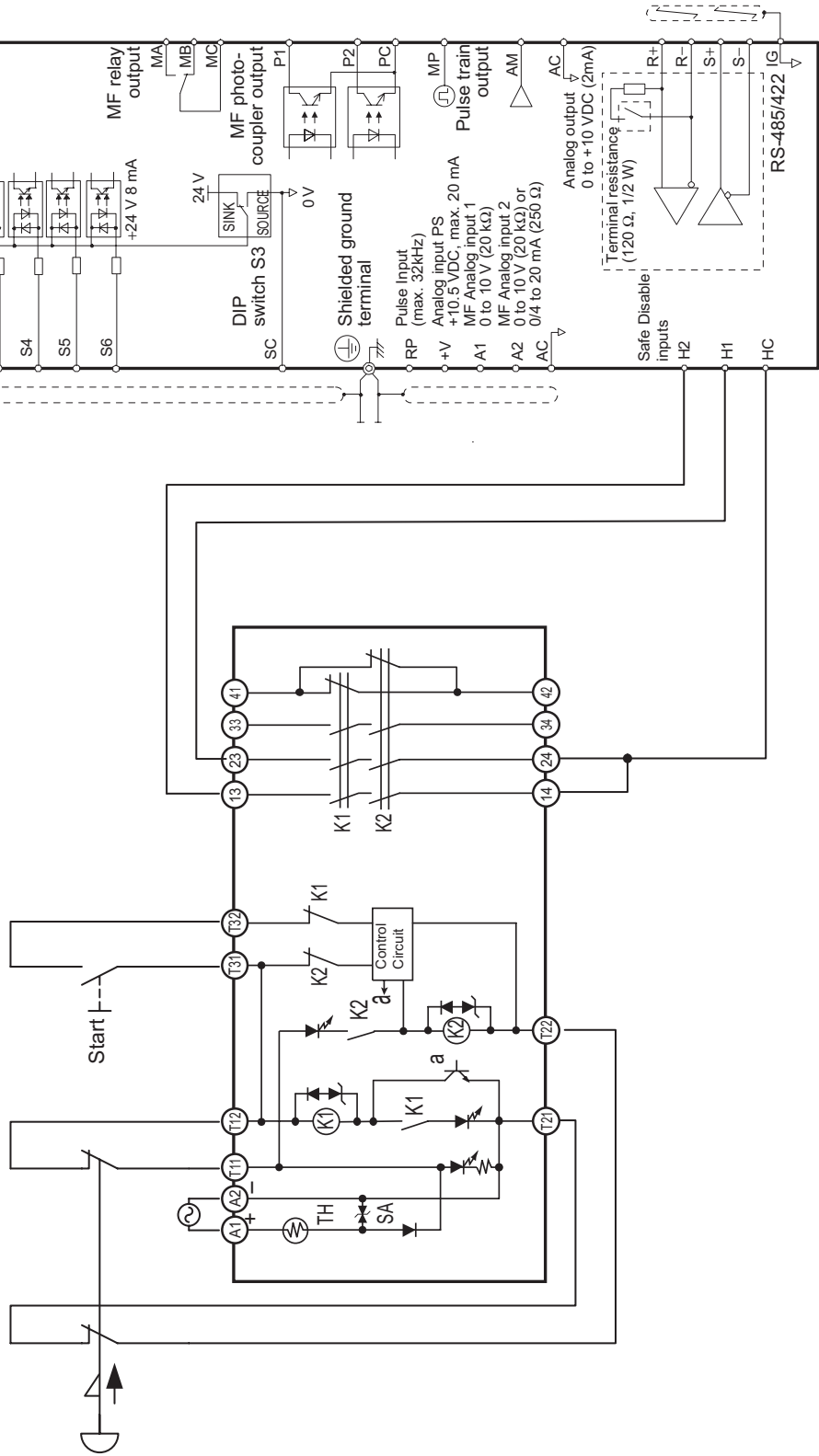

Ordering information

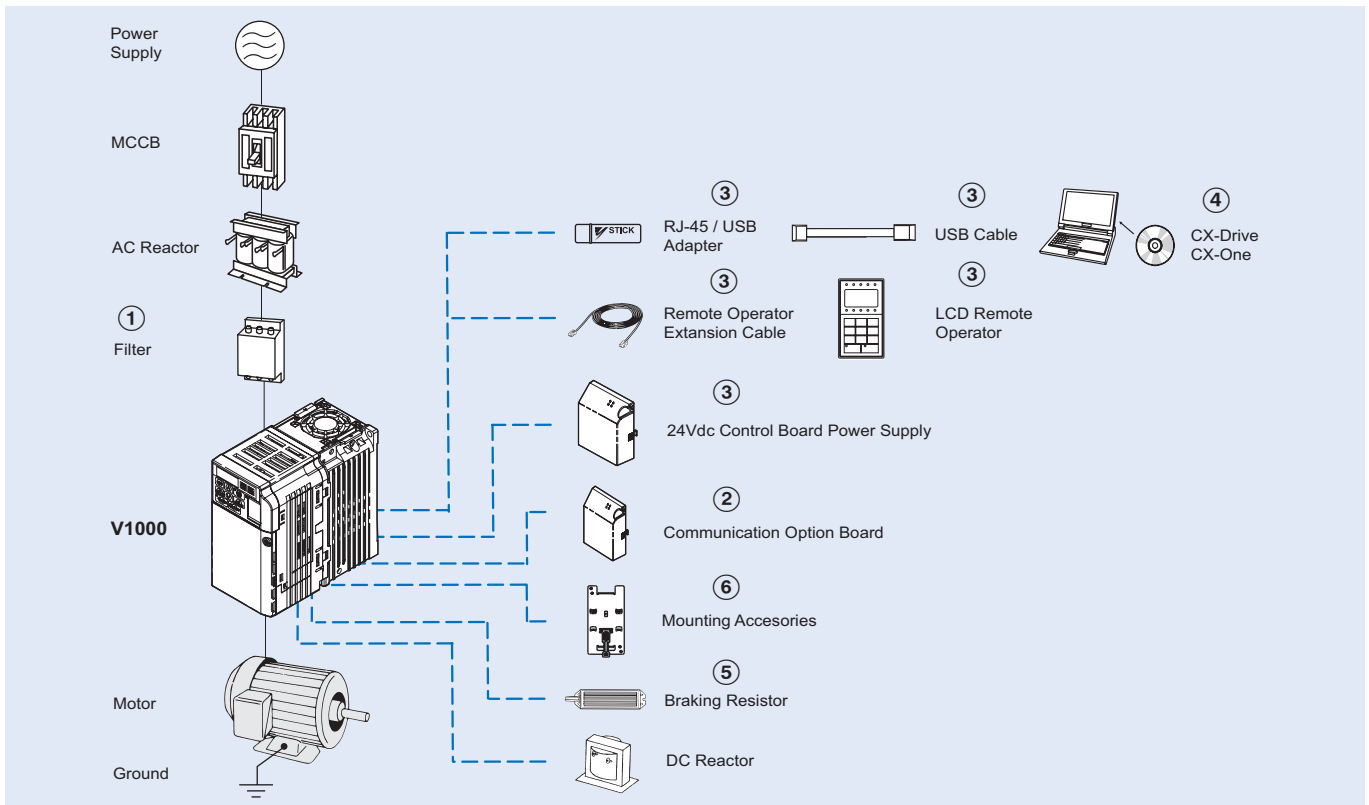

V1000

	Specifications				Model	
	Heavy Duty		Normal Duty		Standard	Built-in filter
1x200 V	0.12 kW	0.8 A	0.18 kW	0.8 A	VZAB0P1BAA	VZAB0P1HAA
	0.25 kW	1.6 A	0.37 kW	1.6 A	VZAB0P2BAA	VZAB0P2HAA
	0.55 kW	3.0 A	0.75 kW	3.5 A	VZAB0P4BAA	VZAB0P4HAA
	1.1 kW	5.0 A	1.1 kW	6.0 A	VZAB0P7BAA	VZAB0P7HAA
	1.5 kW	8.0 A	2.2 kW	9.6 A	VZAB1P5BAA	VZAB1P5HAA
	2.2 kW	11.0 A	3.0 kW	12.0 A	VZAB2P2BAA	VZAB2P2HAA
3x200 V	4.0 kW	17.5 A	5.5 kW	21.0 A	VZAB4P0BAA	VZAB4P0HAA
	0.12 kW	0.8 A	0.18 kW	0.8 A	VZA20P1BAA	VZA20P1HAA
	0.25 kW	1.6 A	0.37 kW	1.6 A	VZA20P2BAA	VZA20P2HAA
	0.55 kW	3.0 A	0.75 kW	3.5 A	VZA20P4BAA	VZA20P4HAA
	1.1 kW	5.0 A	1.1 kW	6.0 A	VZA20P7BAA	VZA20P7HAA
	1.5 kW	8.0 A	2.2 kW	9.6 A	VZA21P5BAA	VZA21P5HAA
	2.2 kW	11.0 A	3.0 kW	12.0 A	VZA22P2BAA	VZA22P2HAA
	4.0 kW	17.5 A	5.5 kW	21.0 A	VZA24P0BAA	VZA24P0HAA
	5.5 kW	25.0 A	7.5 kW	30.0 A	VZA25P5FAA	VZA25P5HAA
	7.5 kW	33.0 A	11.0 kW	40.0 A	VZA27P5FAA	VZA27P5HAA
3x400 V	11 kW	47.0 A	15.0 kW	56.0 A	VZA2011FAA	VZA2011HAA
	15 kW	60.0 A	18.5 kW	69.0 A	VZA2015FAA	VZA2015HAA
	0.2 kW	1.2 A	0.37 kW	1.2 A	VZA40P2BAA	VZA40P2HAA
	0.4 kW	1.8 A	0.75 kW	2.1 A	VZA40P4BAA	VZA40P4HAA
	0.75 kW	3.4 A	1.5 kW	4.1 A	VZA40P7BAA	VZA40P7HAA
	1.5 kW	4.8 A	2.2 kW	5.4 A	VZA41P5BAA	VZA41P5HAA
	2.2 kW	5.5 A	3.0 kW	6.9 A	VZA42P2BAA	VZA42P2HAA
	3.0 kW	7.2 A	3.7 kW	8.8 A	VZA43P0BAA	VZA43P0HAA
	4.0 kW	9.2 A	5.5 kW	11.1 A	VZA44P0BAA	VZA44P0HAA
	5.5 kW	14.8 A	7.5 kW	17.5 A	VZA45P5FAA	VZA45P5HAA
	7.5 kW	18.0 A	11.0 kW	23.0 A	VZA47P5FAA	VZA47P5HAA
11 kW	24.0 A	15.0 kW	31.0 A	VZA4011FAA	VZA4011HAA	
15 kW	31.0 A	18.5 kW	38.0 A	VZA4015FAA	VZA4015HAA	

① Line filters

Voltage	Inverter Model VZ	Line filter Schaffner			Line filter Rasmi		
		Reference	Rated current (A)	Weight (kg)	Reference	Rated current (A)	Weight (kg)
3-Phase 200 VAC	20P1 / 20P2 / 20P4 / 20P7	A1000-FIV2010-SE	10	0.7	A1000-FIV2010-RE	10	0.8
	21P5 / 22P2	A1000-FIV2020-SE	20	0.9	A1000-FIV2020-RE	20	1.1
	24P0	A1000-FIV2030-SE	30	1.0	A1000-FIV2030-RE	30	1.3
	25P5 / 27P5	A1000-FIV2050-SE	Under development		A1000-FIV2060-RE	58	2.4
	2011 / 2015	A1000-FIV2100-SE			A1000-FIV2100-RE	96	4.2
Single-Phase 200 VAC	B0P1 / B0P2 / B0P4	A1000-FIV1010-SE	10	0.5	A1000-FIV1010-RE	10	0.6
	B0P7 / B1P5	A1000-FIV1020-SE	20	0.7	A1000-FIV1020-RE	20	1.0
	B2P2	A1000-FIV1030-SE	30	1.0	A1000-FIV1030-RE	30	1.1
	B4P0	A1000-FIV1040-SE	40	1.1	A1000-FIV1040-RE	40	-
3-Phase 400 VAC	40P2 / 40P4	A1000-FIV3005-SE	5	0.5	A1000-FIV3005-RE	5	1.1
	40P7 / 41P5 / 42P2 / 43P0	A1000-FIV3010-SE	10	0.75	A1000-FIV3010-RE	10	1.1
	44P0	A1000-FIV3020-SE	15	1.0	A1000-FIV3020-RE	20	1.3
	45P5 / 47P5	A1000-FIV3030-SE	Under development		A1000-FIV3030-RE	29	2.1
	4011 / 4015	A1000-FIV3050-SE			A1000-FIV3050-RE	48	2.9

② Communication cards

Type	Model	Description	Function
Communication option board	SI-N3	DeviceNet option card	• Used for running or stopping the inverter, setting or referencing parameters, and monitoring output frequency, output current, or similar items through DeviceNet communication with the host controller.
	SI-P3	PROFIBUS-DP option card	• Used for running or stopping the inverter, setting or referencing parameters, and monitoring output frequency, output current, or similar items through PROFIBUS-DP communication with the host controller.
	SI-S3	Can open option card	• Used for running or stopping the inverter, setting or referencing parameters, and monitoring output frequency, output current, or similar items through CANopen communication with the host controller.
	A1000 - CRT1	CompoNet option card	• Under Development

③ Accessories

Types	Model	Description	Functions
Digital operator	JVOP-180	LCD remote operator	LCD Display operator with language support
	72606-WV001	Remote operator cable (1 m)	Cable for connecting remote operator
	72606-WV003	Remote operator cable (3 m)	
Accessories	JVOP-181	USB converter / USB cable	USB converter unit with copy and backup function
	PS-UDC24	24 VDC option board	24V DC control board power supply

④ Computer software

Types	Model	Description	Installation
Software	CX-drive	Computer software	Configuration and monitoring software tool
	CX-One	Computer software	Configuration and monitoring software tool

⑤ Braking unit, braking resistor unit

Voltage	Max. applicable motor output kW	Inverter		Connectable min. resistance Ω	Braking resistor unit			
		Inverter model VZ			Inverter-mounted type (3 %ED, 10 sec max)			
		Three-phase	Single-phase		ERF-150WJ_	Resistance Ω	No. of used	Braking torque %
200 V (single-/ three-phase)	0.12	20P1	B0P1	300	401	400	1	220
	0.25	20P2	B0P2	300	401	400	1	220
	0.55	20P4	B0P4	200	201	200	1	220
	1.1	20P7	B0P7	120	201	200	1	125
	1.5	21P5	B1P5	60	101	100	1	125
	2.2	22P2	B2P2	60	700	70	1	120
	4.0	24P0	B4P0	32	620	62	1	100
	5.5	25P5	—	16	---			
	7.5	27P5	—	9.6				
	11	2011	—	9.6				
15	2015	—	9.6					
400 V (three- phase)	0.37	40P2	—	750	751	750	1	230
	0.55	40P4	—	750	751	750	1	230
	1.1	40P7	—	510	751	750	1	130
	1.5	41P5	—	240	401	400	1	125
	2.2	42P2	—	200	301	300	1	115
	3.0	43P0	—	100	401	400	2	105
	4.0	44P0	—					
	5.5	45P5	—	32	---			
	7.5	47P5	—	32				
	11	4011	-	20				
15	4015	-	20					

⑥ Mounting accessories

Types	Model	Description	Applicable models
DIN Rail	EZZ08122A	Necessary to mount the inverter on a DIN rail	VZ-20P1/20P2/20P4/20P7 VZ-B0P1/B0P2/B0P4
	EZZ08122B		VZ-21P5/22P2 VZ-B0P7/B1P5 VZ-40P2/40P4/40P7/41P5/42P2
	EZZ08122C		VZ-24P0 VZ-B2P2 VZ-44P0
	EZZ08122D		VZ-B4P0
Heatsink external mounting attachment	100-034-075	Additional items to mount the inverter with the heat-sink out of the panel.	VZ-20P1/20P2 VZ-B0P1/B0P2
	100-034-076		VZ-20P4 VZ-B0P4
	100-034-077		VZ-20P7
	100-034-078		VZ-40P2
	100-034-079		VZ-21P5/22P2 VZ-B1P5 VZ-41P5/42P2/43P0
	100-034-080		VZ-24P0 VZ-B2P2 VZ-44P0
	100-036-357		VZ-B4P0
	100-036-418		VZ-B0P7 VZ-40P2/40P4
	100-036-300		VZ-25P5/27P5 VZ-45P5/47P5
	100-036-301		VZ-2011 VZ-4011/4015
	100-036-302		VZ-2015

Cat. No. I68E-EN-01

In the interest of product improvement, specifications are subject to change without notice.

OMRON EUROPE B.V.

Wegalaan 67-69,
NL-2132 JD, Hoofddorp,
The Netherlands
Phone: +31 23 568 13 00
Fax: +31 23 568 13 88
www.omron-industrial.com