

JUNMA ML-2 SERVO SYSTEM

Save space, save wiring, save time



» Compact size

» Tuning-less concept

» Easy connect

Advanced Industrial Automation

OMRON

A new concept in drive simplicity

The Junma ML-2 ultra-compact servo series draws on our world-leading servo-drive technology to open up new dimensions in drive simplicity. In contrast to ordinary servos, the Junma series requires no tuning. What's more, the servo drives feature a built-in MECHATROLINK-II motion bus, allowing the servos to be easily daisy-chained and controlled through a single cable. Saving time and cabling costs. The result – fast and simple connections, plus fast and simple setting up. And the series' ultra-compact size with a footprint of 67.5 cm² means less installation space and further costs savings.

What more could you want?

The Junma ML-2 series also shares other performance characteristics that have made Omron-Yaskawa servos leading products worldwide. Like fast response, high speed, high torque, high accuracy and proven reliability. Five good reasons for choosing Junma ML-2 servos for all your point-to-point motion-control applications.

Junma ML-2 features

- Compact size means less panel space
- Built-in MECHATROLINK-II motion bus simplifies connection to the controller and saves cost
- Tuning-less technology built-in for immediate start-up
- Drive information transparency (not available with classical pulse or analogue servo control)



Save space, save wiring, save time

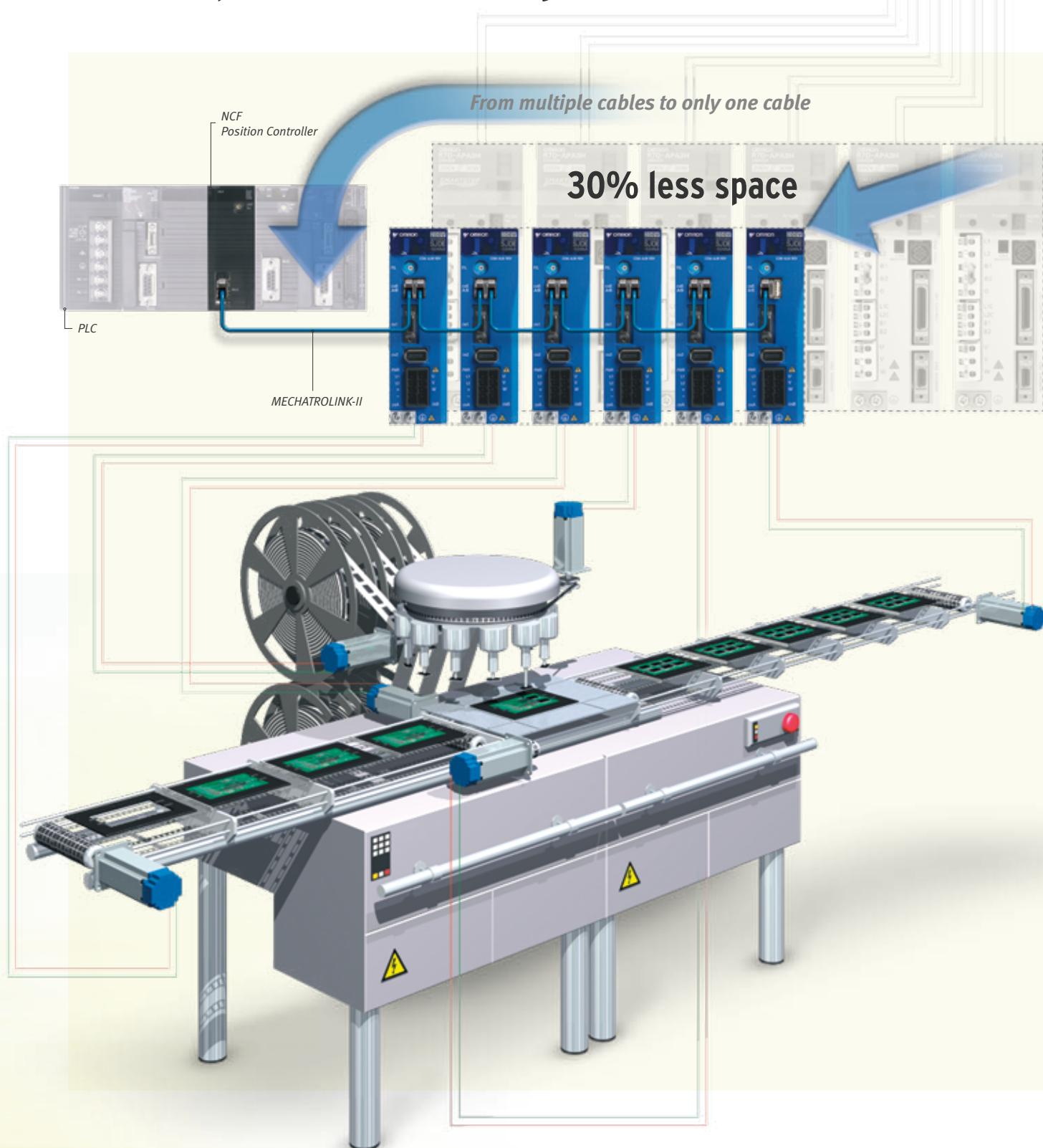

No tuning

The advanced technology embodied in the Junma ML-2 series makes the dream of the no-tuning servo solution a reality. No gain parameters need to be set. Just connect up to the motor and you're ready to go.

Connection simplicity

With their built-in MECHATROLINK-II motion bus, just a single cable is needed to connect servos together. So you not only save on wiring and installation time, you also significantly reduce the chance of connection errors. And reliability is increased since the single-cable connection is much more rugged than a multiple-wiring solution.

Junma ML-2 + NCF the optimum combination

Less is more...

Less space, fewer components and less installation time provides more performance and more flexibility.

The CJ1W-NCF71 Position Control Unit combined with the CJ1 PLC and Junma servo drives offer the best performance/size ratio on the market. The CJ1W-NCF71 is ideal for all point-to-point applications such as control of pick & place systems, gantry robots, electronic assembly equipment and labelling stations. Operation couldn't be simpler with motion commands set directly from the PLC ladder program to provide functions such as interrupt feeding and interpolation.

Easy remote access

What's more, the MECHATROLINK-II network provides full accessibility of drive information, making possible remote access via a PC connected to the PLC for commissioning, troubleshooting and maintenance.



NCF features and benefits

- 16 axes point-to-point positioning controller over MECHATROLINK-II
- Programmed from PLC program
- Easy, fast, reliable setup
- Optimised for positioning applications
- Simplified wiring to drives
- Integration into OMRON Smart Platform: Function Blocks, Smart Active Parts, CX-One
- PLCopen compliant Function Blocks
- Full control of servo drives and full parameter access via MECHATROLINK
- Advanced point-to-point: interpolation of 8 axes (4 axes + 4 axes)

PLCopen

A global standard for industrial control programming, PLCopen provides a standardized programming interface to harmonise the way people design and operate industrial-control software. The PLCopen compliant Function Blocks provided for the CJ1W-NCF71 simplify programming and reduce learning time for new users.



Smart Active Parts (SAPs) Library

The Smart Active Parts (SAPs) Library, also known as the Device Library, consists of screens with functions for Omron HMI terminals. SAPs can be used on screens developed by customers to quickly produce finished screens that interface with various control devices. And since the components are standardized, they also help to improve screen quality.

UP TO 16 AXES

SJDE-□□ANA-OY, SJME-□

Junma ML-II Servo system

The ideal servo family for multi-axis positioning applications

- Ultra compact size drive, height of 150 mm
- MECHATROLINK-II motion bus port build-in
- Tuning-less technology, no gain parameters need to be set
- Peak torque 300% of nominal during 3 seconds
- Full drive control via Mechatrolink-II motion bus
- Mechatrolink simplifies wiring and reduces installation time
- High response, high speed, high torque and high accuracy
- Access to the complete system from one point



Ratings

- 230 VAC Single-phase 100 W to 750 W (2.39 Nm)

System Configuration

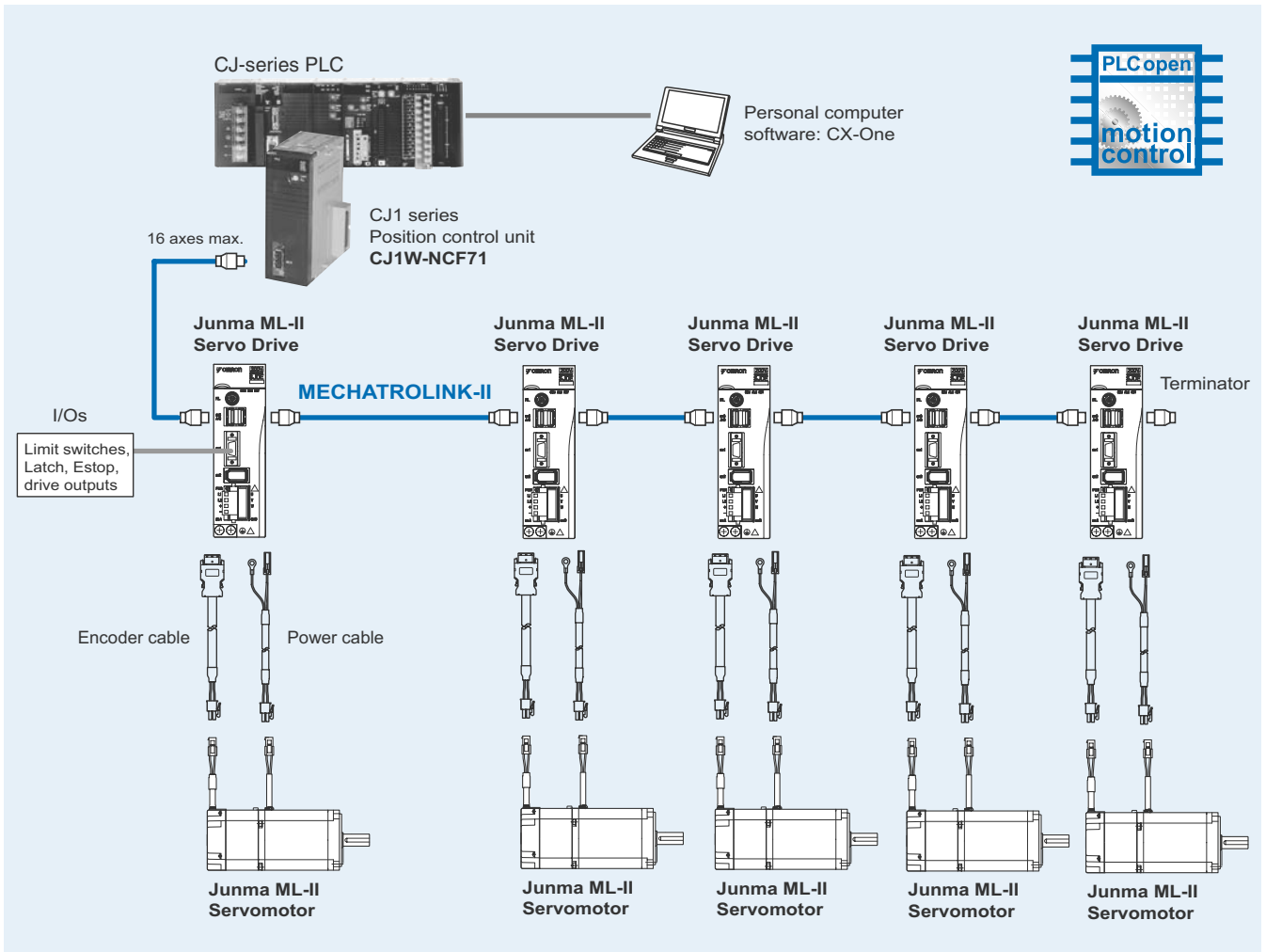

Servomotor / Servo Drive Combination

Junma Servomotor				Junma ML-2 servo drive 230V (1-phase)		
	Voltage	Rated Torque	Capacity	Model without brake	Model with brake	
	200 V	0.318 Nm	100 W	SJME-01AMB41-OY	SJME-01AMB4C-OY	SJDE-01ANA-OY
		0.637 Nm	200 W	SJME-02AMB41-OY	SJME-02AMB4C-OY	SJDE-02ANA-OY
		1.27 Nm	400 W	SJME-04AMB41-OY	SJME-04AMB4C-OY	SJDE-04ANA-OY
		2.39 Nm	750 W	SJME-08AMB41-OY	SJME-08AMB4C-OY	SJDE-08ANA-OY

Motor Type Designation

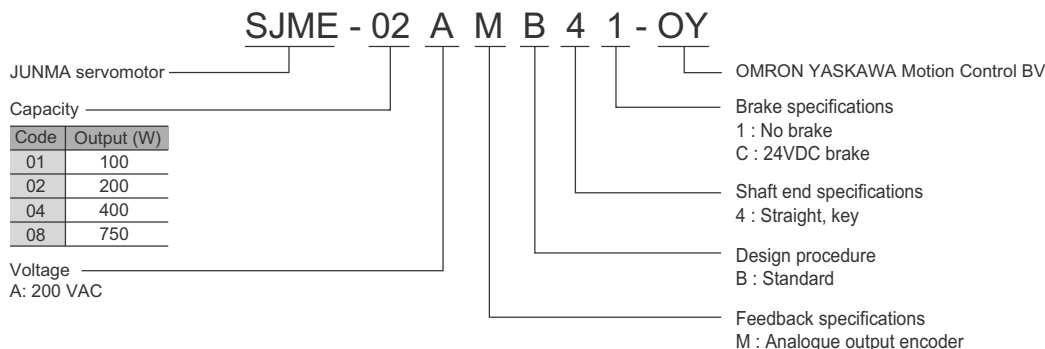

Servomotor Specifications

Voltage		230 V			
Servomotor Model SJDE- □		01A□	02A□	04A□	08A□
Rated Output ^{*1}	W	100	200	400	750
Rated Torque ^{*1, *2}	N·m	0.318	0.637	1.27	2.39
Instantaneous Peak Torque ^{*1}	N·m	0.955	1.91	3.82	7.16
Rated Current ^{*1}	Arms	0.84	1.1	2.0	3.7
Instantaneous Max. Current ^{*1}	Arms	2.5	3.3	6.0	11.1
Rated Speed ^{*1}	min ⁻¹	3000			
Max. Speed ^{*1}	min ⁻¹	4500			
Torque Constant	N·m/Arms	0.413	0.645	0.682	0.699
Rotor Moment of Inertia (JM)	kg·m ² ×10 ⁻⁴	0.0634	0.330	0.603	1.50
Rated Power Rate	kW/s	16.0	12.3	26.7	38.1
Rated Angular Acceleration	rad/s ²	50200	19300	21100	15900
Encoder	Standard	Analogue output encoder (13 bits incremental equivalent)			
Holding Brake Moment of Inertia J	kg·m ² ×10 ⁻⁴	0.0075	0.064		0.171
Basic Specifications	Time Rating	Continuous			
	Thermal Class	Class B			
	Vibration Class	15µm or below			
	Withstand Voltage	1500 VAC for one minute			
	Insulation resistance	500 VDC, 10 MΩ min.			
	Enclosure	Totally-enclosed, self-cooled, IP55 (excluding shaft opening and connectors)			
	Vibration Resistance	Vibration acceleration 49 m/s ²			
	Usage / storage temperature	0 to +40° C / -20 to 60° C without freezing			
	Usage / storage humidity	20 to 80% RH (non-condensing)			
	Altitude	1000 m or less above sea level			
Mounting	Flange-mounted				

Note: *1. These items and speed/torque characteristics quoted in combination with an SJDE servo drive are at an armature winding temperature of 100° C. Other values quoted at 20° C.
*2: The rated torques listed here are the values for the continuous allowable torque at 40° C with an aluminum heatsink (250 mm x 250 mm x 6 mm) attached.

Torque-Speed Characteristics

(A : Continuous Duty Zone B : Intermittent Duty Zone)

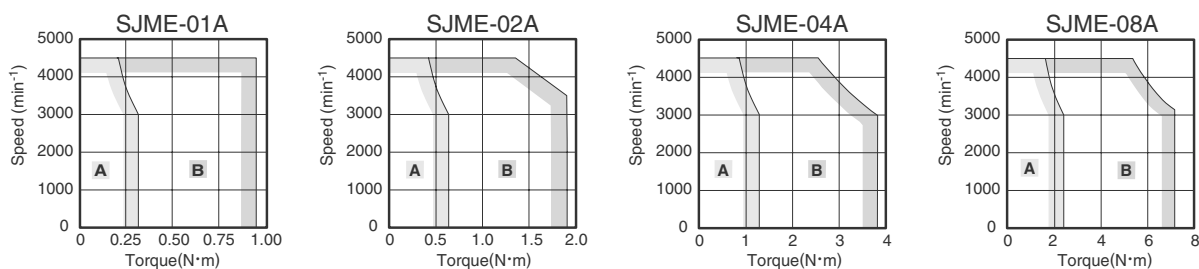

Servo Drive Type Designation

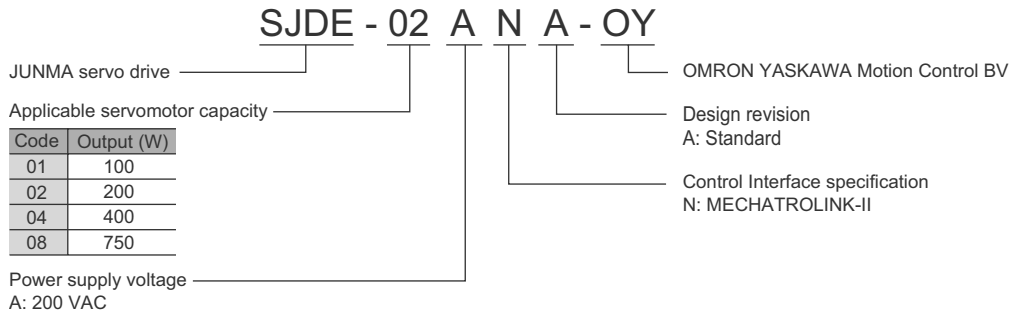

Servo Drive Specifications

Servo Drive Type	SJDE-□	01ANA-OY	02ANA-OY	04ANA-OY	08ANA-S-OY	
Applicable servomotor	SJME-□	01A□	02A□	04A□	08A□	
Basic specifications	Max. Applicable Motor capacity	W	100	200	400	750
	Continuous output current	Arms	0.84	1.1	2.0	3.7
	Max. output current	Arms	2.5	3.3	6.0	11.1
	Input power supply (Main circuit and control circuit)	Voltage	Single-phase, 200 to 230 VAC, + 10 to -15% (50/60 Hz)			
		Capacity KVA	0.40	0.75	1.2	2.2
	Control Method	PWM control, sine wave current drive system				
	Feedback	Analogue output encoder (13 bits incremental equivalent)				
	Allowable load inertia	kg·m ²	0.6 × 10 ⁻⁴	3.0 × 10 ⁻⁴	5.0 × 10 ⁻⁴	10.0 × 10 ⁻⁴
	Usage / storage temperature	0 to +55° C / -20 to 70° C				
	Usage / storage humidity	90% RH or less (non-condensing)				
	Altitude	1000 m or less above sea level				
	Vibration/shock Resistance	4.9 m/s ² (0.5G) / 19.6 m/s ² (2G)				
	Configuration	Base mounted				
	Approx. mass	Kg	1.0			1.4
	Built-in functions	Dynamic brake (DB)	Operated at main power OFF, servo alarm, servo OFF. (OFF after motor stops; ON when motor power is off.)			
Regenerative processing		Optional (If the regenerated energy is too large, install a regenerative unit JUSP-RG08D)				
Over-travel (OT) prevention function		P_OT, N_OT				
Display functions		4 LEDs (PWR, RDY, COM, ALM)				
MECHATROLINK monitoring function		MECHATROLINK-II under communication : COM LED (Light ON)				
Servo ON/OFF monitoring function		At Servo OFF : RDY LED (Light OFF), at Servo ON : RDY LED (Light ON/OFF)				
Power supply state monitor function		Control / main-circuit power-supply OFF state: PWR LED (light OFF)				
		Control / main-circuit power-supply ON state: PWR LED (light ON)				
Electronic gearing		0.01 < A/B < 100				
MECHATROLINK Communication		Comm. protocol	MECHATROLINK-II			
		Transmission rate	10 Mbps			
		Transmission cycle	1 ms, 1.5 ms, 2 ms, 3 ms, 4 ms			
	Data length	17 byte and 32 byte				
Command input	MECHATROLINK communication	MECHATROLINK-II command input, MECHATROLINK-II system command and servo command are supported.				
Sequence Input signal	Fixed input	5 points (fixed layout: external latch signal, zero return reduced speed signal, forward drive inhibiting signal, reverse drive inhibiting signal, emergency stop signal)				
Sequence Output signal	Fixed output	2 points (fixed layout: servo alarm, brake interlock)				

Dimensions

Servomotors

SJME-01 (200 V, 100 W)

Model	L	LL	Approx. Mass (kg)
SJME-01AMB41-OY	119	94	0.5
SJME-01AMB4C-OY	164	139	0.8

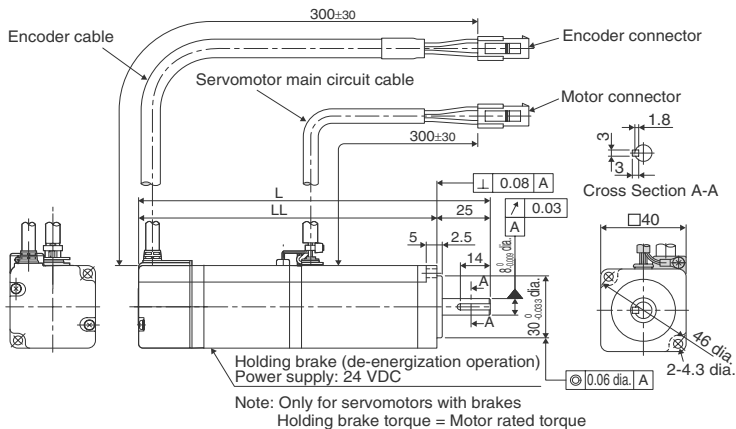

Units: mm

SJME-02, 04, 08 (200 V, 200 to 750 W)

Model	L	LL	LR	LG	LE	S	LB	LC	LD	LF	LA	LZ	QK	Approx. Mass (kg)
SJME-02AMB41-OY	125.5	95.5	30	6	3	14 ⁰ _{-0.011}	50 ⁰ _{-0.039}	60	-	-	70	5.5	20	0.9
SJME-02AMB4C-OY	165.5	135.5												1.5
SJME-04AMB41-OY	148.5	118.5												1.3
SJME-04AMB4C-OY	188.5	158.5												1.9
SJME-08AMB41-OY	173	133	40	8	3	16 ⁰ _{-0.011}	70 ⁰ _{-0.046}	80	35	20	90	7	30	2.6
SJME-08AMB4C-OY	216	176												3.5

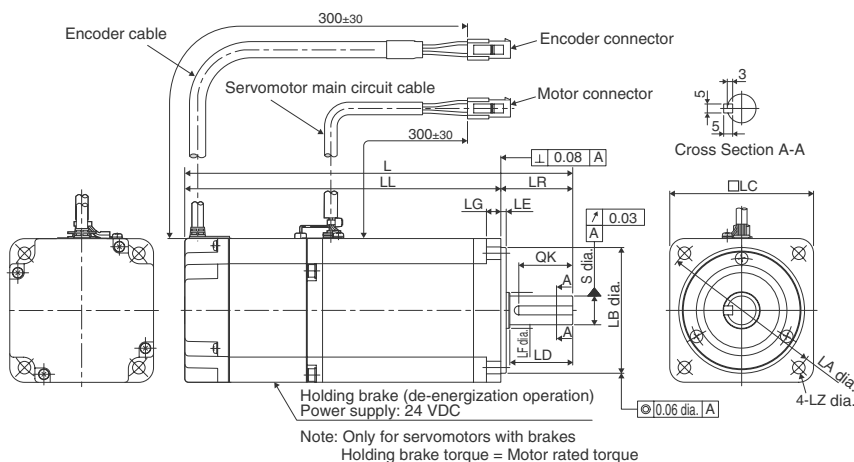

Units: mm

Servomotor connectors

Encoder Connector Specifications

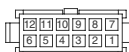

Plug: 5559-12P-210
Terminal: 5558T2(chained) or 5558T2L(detached) (Manufacturer: Molex Japan Co., Ltd)

1	PG5V	Red
2	PG0V(GND)	Black
3	Phase A+	Blue
4	Phase A-	Blue/White
5	Phase B+	Yellow
6	Phase B-	Yellow/White
7	Phase /Z	Purple
8	Phase U	Gray
9	Phase V	Green
10	Phase W	Orange
11	-	-
12	FG	Shield

Motor Connector Specifications



Plug: 5559-06P-210
Terminal (No.1 to 3, 5, 6): 5558T(chained) or 5558TL(detached)
Grounding Pin (No.4): 30490-2002(chained) or 30490-2012 (detached) (Manufacturer: Molex Japan Co., Ltd)

	No brake		With brake	
1	Phase U	Red	Phase U	Red
2	Phase V	White	Phase V	White
3	Phase W	Blue	Phase W	Blue
4	F G	Green/Yellow	F G	Green/Yellow
5	-	-	Brake	Red
6	-	-	Brake	Black

Servo Drives

SJDE-01, 02, 04ANA-OY (200 V, 100 to 400 W)

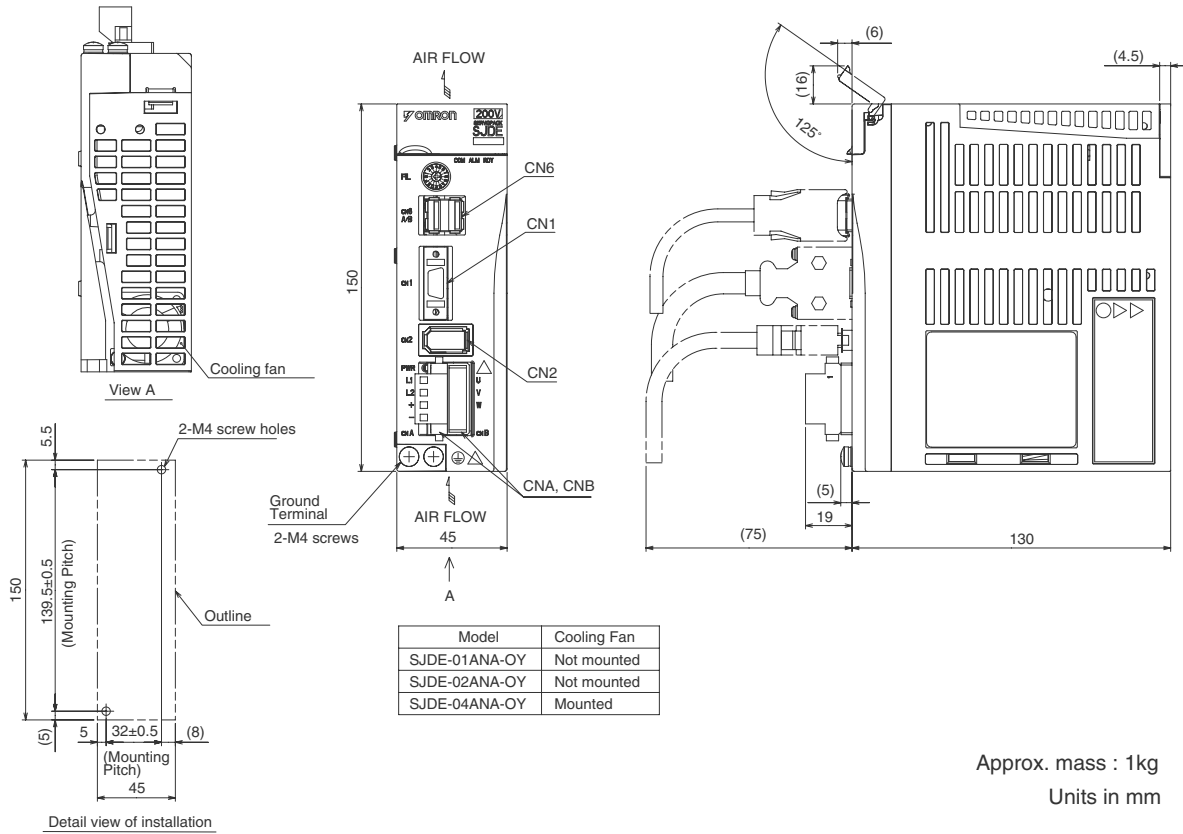

SJDE-08ANA-OY (200 V, 750 W)

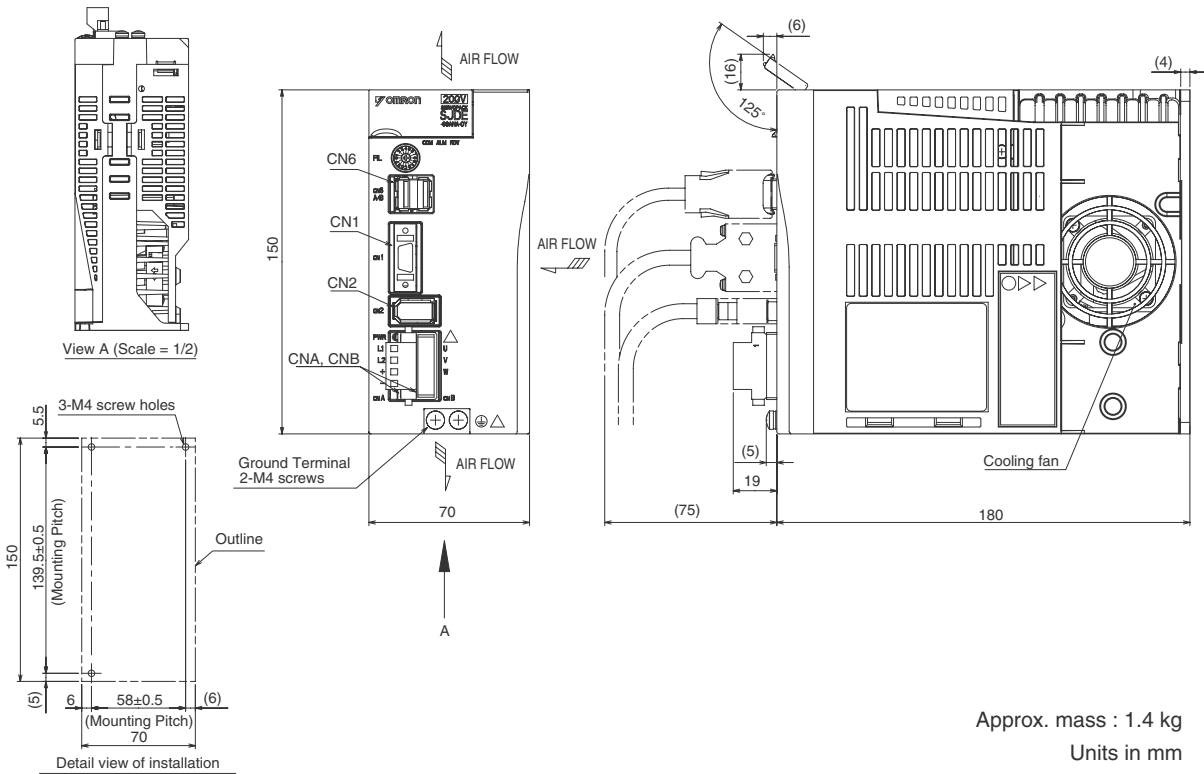

Ordering Information

System Configuration

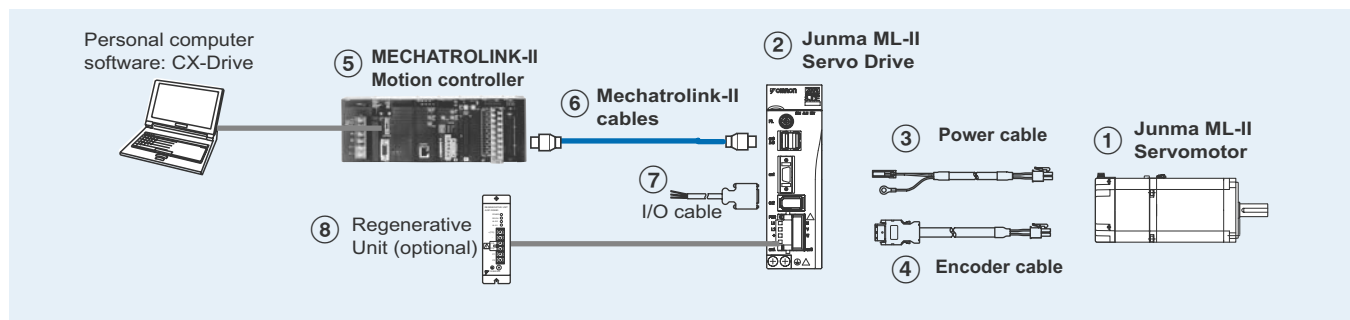

Servomotors and Servo drives

Symbol	Specifications				① Servomotor model	② Servo drive model	
	Voltage	Encoder and Design	Rated Torque	Capacity			
①②	1 Phase 200 VAC	Analogue Incremental Encoder (13 bit)	Without brake	0.318 Nm	100 W	SJME-01AMB41-OY	SJDE-01ANA-OY
				0.637 Nm	200 W	SJME-02AMB41-OY	SJDE-02ANA-OY
			1.27 Nm	400 W	SJME-04AMB41-OY	SJDE-04ANA-OY	
			2.39 Nm	750 W	SJME-08AMB41-OY	SJDE-08ANA-OY	
		Straight shaft with key	With brake	0.318 Nm	100 W	SJME-01AMB4C-OY	SJDE-01ANA-OY
				0.637 Nm	200 W	SJME-02AMB4C-OY	SJDE-02ANA-OY
			1.27 Nm	400 W	SJME-04AMB4C-OY	SJDE-04ANA-OY	
			2.39 Nm	750 W	SJME-08AMB4C-OY	SJDE-08ANA-OY	

Power and encoder cables

Symbol	Specifications	Model	Appearance	
③	Power cable for Junma servomotors without brake SJME-0□AMB41-OY	3 m	JZSP-CHM000-03	
		5 m	JZSP-CHM000-05	
		10 m	JZSP-CHM000-10	
		15 m	JZSP-CHM000-15	
		20 m	JZSP-CHM000-20	
	Power cable for Junma servomotors with brake SJME-0□AMB4C-OY	3 m	JZSP-CHM030-03	
		5 m	JZSP-CHM030-05	
		10 m	JZSP-CHM030-10	
		15 m	JZSP-CHM030-15	
		20 m	JZSP-CHM030-20	
④	Encoder cable for Junma servomotors SJME-0□AMB4□-OY	3 m	JZSP-CHP800-03	
		5 m	JZSP-CHP800-05	
		10 m	JZSP-CHP800-10	
		15 m	JZSP-CHP800-15	
		20 m	JZSP-CHP800-20	

Mechatrolink-II Motion controllers

Symbol	Name	Model
⑤	Position Controller Unit for CJ1 PLC	CJ1W-NCF71
	Position Controller Unit for CS1 PLC	CS1W-NCF71
	Stand-alone advanced motion controller	Trajexia TJ1-□

Regenerative Unit Model (Option)

Symbol	Specifications	Model
⑧	External regenerative unit	JUSP-RG08D

Mechatrolink-II cables

Symbol	Specifications	Model	
⑥	Mechatrolink-II Terminator resistor	JEPMC-W6022	
	Mechatrolink-II Cables	0.5 m	JEPMC-W6003-A5
		1 m	JEPMC-W6003-01
		3 m	JEPMC-W6003-03
		5 m	JEPMC-W6003-05
		10 m	JEPMC-W6003-10
		20 m	JEPMC-W6003-20
30 m	JEPMC-W6003-30		

Connectors

Specification	Model
Control I/O connector (for CN1)	R7A-CNA01R

Computer Software

Specifications	Model
Configuration and monitoring software tool via ML2 (CX-Drive version 1.3 or higher)	CX-DRIVE

Cables for I/Os (for CN1)

Symbol	Specifications	Model	
⑦	Cable for servo drive I/O signals	1 m	JZSP-CHI003-01
		2 m	JZSP-CHI003-02
		3 m	JZSP-CHI003-03

OMRON EUROPE B.V. Wegalaan 67-69, NL-2132 JD, Hoofddorp, The Netherlands. Tel: +31 (0) 23 568 13 00 Fax: +31 (0) 23 568 13 88 www.omron-industrial.com

Austria

Tel: +43 (0) 1 80 19 00
www.omron.at

Belgium

Tel: +32 (0) 2 466 24 80
www.omron.be

Czech Republic

Tel: +420 234 602 602
www.omron.cz

Denmark

Tel: +45 43 44 00 11
www.omron.dk

Finland

Tel: +358 (0) 207 464 200
www.omron.fi

France

Tel: +33 (0) 1 56 63 70 00
www.omron.fr

Germany

Tel: +49 (0) 2173 680 00
www.omron.de

Hungary

Tel: +36 (0) 1 399 30 50
www.omron.hu

Italy

Tel: +39 02 326 81
www.omron.it

Middle East & Africa

Tel: +31 (0) 23 568 11 00
www.omron-industrial.com

Netherlands

Tel: +31 (0) 23 568 11 00
www.omron.nl

Norway

Tel: +47 (0) 22 65 75 00
www.omron.no

Poland

Tel: +48 (0) 22 645 78 60
www.omron.pl

Portugal

Tel: +351 21 942 94 00
www.omron.pt

Russia

Tel: +7 495 745 26 64
www.omron.ru

Spain

Tel: +34 913 777 900
www.omron.es

Sweden

Tel: +46 (0) 8 632 35 00
www.omron.se

Switzerland

Tel: +41 (0) 41 748 13 13
www.omron.ch

Turkey

Tel: +90 (0) 216 474 00 40
www.omron.com.tr

United Kingdom

Tel: +44 (0) 870 752 08 61
www.omron.co.uk

More Omron representatives

www.omron-industrial.com

Authorised Distributor:

Control Systems

• Programmable logic controllers • Human-machine interfaces • Remote I/O

Motion & Drives

• Motion controllers • Servo systems • Inverters

Control Components

• Temperature controllers • Power supplies • Timers • Counters • Programmable relays
• Digital panel indicators • Electromechanical relays • Monitoring products • Solid-state relays
• Limit switches • Pushbutton switches • Low voltage switch gear

Sensing & Safety

• Photoelectric sensors • Inductive sensors • Capacitive & pressure sensors • Cable connectors
• Displacement & width-measuring sensors • Vision systems • Safety networks • Safety sensors
• Safety units/relay units • Safety door/guard lock switches